

53-1002180-08
19 September 2014



Brocade DCX 8510-8 Backbone

Hardware Reference Manual

BROCADE

© 2014, Brocade Communications Systems, Inc. All Rights Reserved.

Brocade, the B-wing symbol, Brocade Assurance, ADX, AnyIO, DCX, Fabric OS, FastIron, HyperEdge, ICX, MLX, MyBrocade, NetIron, OpenScript, VCS, VDX, and Vyatta are registered trademarks, and The Effortless Network and the On-Demand Data Center are trademarks of Brocade Communications Systems, Inc., in the United States and in other countries. Other brands and product names mentioned may be trademarks of others.

Notice: This document is for informational purposes only and does not set forth any warranty, expressed or implied, concerning any equipment, equipment feature, or service offered or to be offered by Brocade. Brocade reserves the right to make changes to this document at any time, without notice, and assumes no responsibility for its use. This informational document describes features that may not be currently available. Contact a Brocade sales office for information on feature and product availability. Export of technical data contained in this document may require an export license from the United States government.

The authors and Brocade Communications Systems, Inc. assume no liability or responsibility to any person or entity with respect to the accuracy of this document or any loss, cost, liability, or damages arising from the information contained herein or the computer programs that accompany it.

The product described by this document may contain open source software covered by the GNU General Public License or other open source license agreements. To find out which open source software is included in Brocade products, view the licensing terms applicable to the open source software, and obtain a copy of the programming source code, please visit <http://www.brocade.com/support/oscd>.

Contents

- Preface..... 7**
 - Document conventions.....7
 - Text formatting conventions.....7
 - Command syntax conventions.....7
 - Notes, cautions, and warnings.....8
 - Brocade resources.....9
 - Contacting Brocade Technical Support.....9
 - Document feedback.....10

- About This Document..... 11**
 - Supported hardware and software.....11
 - What's new in this document.....11

- Brocade DCX 8510-8 Overview..... 13**
 - Brocade DCX 8510-8 features.....13
 - Brocade DCX 8510-8 hardware components.....14
 - Port side of the Brocade DCX 8510-8.....15
 - Nonport side of the Brocade DCX 8510-8.....16
 - Brocade DCX 8510-8 blades.....17
 - High availability.....19
 - Reliability.....19
 - Serviceability.....20
 - Software features.....20
 - Security.....20
 - Network manageability.....21

- Installation of the Brocade DCX 8510-8..... 23**
 - Time and items required.....23
 - Preparing for the Brocade DCX 8510-8 installation.....24
 - Unpacking and installing the Brocade DCX 8510-8.....25
 - Items included with the Brocade DCX 8510-8.....26
 - Providing power to the Brocade DCX 8510-8 Backbone.....27
 - Port numbering.....27
 - Chassis slots.....29
 - Cable management.....29
 - High-density cabling.....30
 - Qualified cables for the FC8-64 port blade.....31
 - Cable types supported on the FC16-64 port blade.....32
 - Installing ICL cables.....33

- Logging In and Configuring the Brocade DCX 8510-8..... 35**
 - Configuring the Brocade DCX 8510-8.....35
 - Establishing a serial connection to the Brocade DCX 8510-8.....36
 - Logging in to the serial console port.....37
 - Configuring the IP addresses.....38
 - Logging off the serial console port and disconnecting the serial cable.....39

| | |
|--|-----------|
| Establishing an Ethernet connection to the Brocade DCX 8510-8..... | 39 |
| Customizing a switch name..... | 40 |
| Customizing a chassis name..... | 40 |
| Setting the domain ID..... | 40 |
| Setting the date and time..... | 41 |
| Setting the date..... | 41 |
| Setting the time zone..... | 41 |
| Synchronizing local time..... | 42 |
| Verifying the PID mode..... | 43 |
| Determining installed software licenses..... | 43 |
| Installing transceivers and attaching cables..... | 43 |
| Installing SFP+ and mSFP transceivers and cables..... | 44 |
| Qualified transceivers for the FC16-64 port blade and the core blades..... | 44 |
| Installing QSFP transceivers and cables..... | 45 |
| Managing cables..... | 46 |
| Verifying correct operation and backing up the configuration..... | 47 |
| Powering off the Brocade DCX 8510-8..... | 48 |
| Monitoring System Components..... | 49 |
| Monitoring overview..... | 49 |
| Determining the status of a port or application blade..... | 54 |
| Blade illustrations..... | 54 |
| Determining the status of a control processor blade (CP8)..... | 65 |
| Determining the status of a core switch blade (CR16-8)..... | 67 |
| Determining the status of a power supply..... | 69 |
| Determining the status of a blower assembly..... | 70 |
| Determining the status of a WWN card..... | 72 |
| Removal and Replacement Procedures..... | 75 |
| Introduction..... | 75 |
| ESD precautions..... | 75 |
| Chassis door removal and replacement..... | 76 |
| Time and items required..... | 76 |
| Removing a chassis door..... | 76 |
| Replacing a chassis door..... | 77 |
| Cable management comb removal and replacement..... | 77 |
| Time and items required..... | 77 |
| Removing a cable management comb..... | 77 |
| Replacing a cable management comb..... | 78 |
| Port, application, and encryption blade removal and replacement..... | 78 |
| Time and items required..... | 79 |
| Removing a blade..... | 80 |
| Replacing a blade..... | 81 |
| Blade filler panel removal and replacement..... | 82 |
| Removing a filler panel..... | 82 |
| Replacing a filler panel..... | 83 |
| Control processor blade (CP8) removal and replacement..... | 84 |
| Time and items required..... | 84 |
| Faulty CP blade indicators..... | 84 |
| Recording critical Brocade DCX 8510-8 information..... | 85 |
| Removing a control processor blade (CP8)..... | 86 |
| Replacing a control processor blade (CP8)..... | 87 |
| Verifying operation of the new CP blade..... | 88 |
| Completing the replacement..... | 91 |
| Core switch blade (CR16-8) removal and replacement..... | 92 |

| | |
|--|-----|
| Time and items required..... | 92 |
| Faulty core switch blade indicators..... | 92 |
| Removing a core switch blade (CR16-8)..... | 92 |
| Replacing a core switch blade (CR16-8)..... | 94 |
| Power supply removal and replacement..... | 95 |
| Time and items required..... | 95 |
| Identifying power supplies..... | 95 |
| Removing a power supply..... | 96 |
| Replacing a power supply..... | 97 |
| Blower assembly removal and replacement..... | 98 |
| Time and items required..... | 98 |
| Removing a blower assembly | 98 |
| Replacing a blower assembly..... | 99 |
| WWN card removal and replacement..... | 99 |
| Time and items required..... | 100 |
| Verifying the need for replacement..... | 100 |
| Preparing for the WWN card replacement..... | 100 |
| Removing the WWN card and WWN bezel (logo plate)..... | 101 |
| Replacing the WWN card and WWN bezel (logo plate)..... | 103 |
| Transceiver removal and replacement..... | 103 |
| Time Required..... | 104 |
| Items Required..... | 104 |
| Removing an SFP+ transceiver..... | 104 |
| Replacing an SFP+ transceiver..... | 105 |
| Removing and replacing an mSFP optical transceiver..... | 106 |
| Removing and replacing a QSFP optical transceiver..... | 107 |
| Qualified transceivers for the FC16-64 port blade and the core blades..... | 108 |
| Inter-chassis link (ICL) cable removal and replacement..... | 108 |
| Time and items required..... | 110 |
| Removing an ICL cable..... | 110 |
| Replacing an ICL cable..... | 110 |
| Possible ICL configurations..... | 110 |
| Brocade DCX 8510-8 chassis removal and replacement..... | 113 |
| Time and items required..... | 114 |
| Faulty Brocade DCX 8510-8 chassis indicators..... | 114 |
| Recording critical Brocade DCX 8510-8 and SAN information..... | 115 |
| Disconnecting from network and fabric..... | 117 |
| Removing components from the chassis..... | 118 |
| Installing the replacement chassis..... | 118 |
| Installing components into the new chassis..... | 119 |
| Downloading the configuration..... | 120 |
| Verifying correct operation of system..... | 120 |
| Reconnecting the system to the network and fabric..... | 122 |
| Verifying correct configuration of the fabric..... | 122 |
| Cable routing table..... | 123 |

| | |
|---|------------|
| Application and Encryption Blades..... | 127 |
| Introduction..... | 127 |
| FS8-18 blade..... | 127 |
| FX8-24 blade..... | 127 |
| FCOE10-24 blade..... | 129 |
| Limitations of FCOE10-24 blade..... | 130 |

| | |
|---|------------|
| Diagnostics and Troubleshooting..... | 131 |
| Introduction..... | 131 |

| | |
|---|------------|
| Obtaining chassis and component status..... | 131 |
| Interpreting POST and boot results..... | 132 |
| POST..... | 132 |
| Boot..... | 133 |
| Diagnostics..... | 133 |
| Troubleshooting..... | 134 |
| | |
| Port Numbering Template..... | 137 |
| | |
| Regulatory Statements..... | 149 |
| Regulatory compliance..... | 149 |
| FCC warning (US only)..... | 149 |
| KCC statement (Republic of Korea)..... | 149 |
| VCCI statement (Japan)..... | 149 |
| Power-cord notice (Japan, Denan)..... | 150 |
| BSMI statement (Taiwan)..... | 150 |
| CE statement..... | 150 |
| Canadian requirements..... | 151 |
| German statement..... | 151 |
| Regulatory compliance standards..... | 151 |
| Environmental regulation compliance..... | 152 |
| China RoHS..... | 152 |
| | |
| Brocade DCX 8510 Technical Specifications..... | 153 |
| | |
| Caution and Danger Notices..... | 167 |
| Cautions..... | 167 |
| Danger Notices..... | 168 |
| | |
| Index..... | 173 |

Preface

- Document conventions..... 7
- Brocade resources..... 9
- Contacting Brocade Technical Support..... 9
- Document feedback..... 10

Document conventions

The document conventions describe text formatting conventions, command syntax conventions, and important notice formats used in Brocade technical documentation.

Text formatting conventions

Text formatting conventions such as boldface, italic, or Courier font may be used in the flow of the text to highlight specific words or phrases.

| Format | Description |
|---------------------------|--|
| bold text | Identifies command names Identifies keywords and operands Identifies the names of user-manipulated GUI elements Identifies text to enter at the GUI |
| <i>italic text</i> | Identifies emphasis Identifies variables and modifiers Identifies paths and Internet addresses Identifies document titles |
| <code>Courier font</code> | Identifies CLI output Identifies command syntax examples |

Command syntax conventions

Bold and italic text identify command syntax components. Delimiters and operators define groupings of parameters and their logical relationships.

| Convention | Description |
|--------------------|--|
| bold text | Identifies command names, keywords, and command options. |
| <i>italic text</i> | Identifies a variable. |

| Convention | Description |
|---------------|---|
| value | In Fibre Channel products, a fixed value provided as input to a command option is printed in plain text, for example, --show WWN . |
| [] | Syntax components displayed within square brackets are optional. Default responses to system prompts are enclosed in square brackets. |
| { x y z } | A choice of required parameters is enclosed in curly brackets separated by vertical bars. You must select one of the options. In Fibre Channel products, square brackets may be used instead for this purpose. |
| x y | A vertical bar separates mutually exclusive elements. |
| < > | Nonprinting characters, for example, passwords, are enclosed in angle brackets. |
| ... | Repeat the previous element, for example, <i>member[member...]</i> . |
| \ | Indicates a "soft" line break in command examples. If a backslash separates two lines of a command input, enter the entire command at the prompt without the backslash. |

Notes, cautions, and warnings

Notes, cautions, and warning statements may be used in this document. They are listed in the order of increasing severity of potential hazards.

NOTE

A Note provides a tip, guidance, or advice, emphasizes important information, or provides a reference to related information.

ATTENTION

An Attention statement indicates a stronger note, for example, to alert you when traffic might be interrupted or the device might reboot.



CAUTION

A Caution statement alerts you to situations that can be potentially hazardous to you or cause damage to hardware, firmware, software, or data.



DANGER

A Danger statement indicates conditions or situations that can be potentially lethal or extremely hazardous to you. Safety labels are also attached directly to products to warn of these conditions or situations.

Brocade resources

Visit the Brocade website to locate related documentation for your product and additional Brocade resources.

You can download additional publications supporting your product at www.brocade.com. Select the Brocade Products tab to locate your product, then click the Brocade product name or image to open the individual product page. The user manuals are available in the resources module at the bottom of the page under the Documentation category.

To get up-to-the-minute information on Brocade products and resources, go to [MyBrocade](#). You can register at no cost to obtain a user ID and password.

Release notes are available on [MyBrocade](#) under Product Downloads.

White papers, online demonstrations, and data sheets are available through the [Brocade website](#).

Contacting Brocade Technical Support

As a Brocade customer, you can contact Brocade Technical Support 24x7 online, by telephone, or by e-mail. Brocade OEM customers contact their OEM/Solutions provider.

Brocade customers

For product support information and the latest information on contacting the Technical Assistance Center, go to <http://www.brocade.com/services-support/index.html>.

If you have purchased Brocade product support directly from Brocade, use one of the following methods to contact the Brocade Technical Assistance Center 24x7.

| Online | Telephone | E-mail |
|--|--|--|
| <p>Preferred method of contact for non-urgent issues:</p> <ul style="list-style-type: none"> • My Cases through MyBrocade • Software downloads and licensing tools • Knowledge Base | <p>Required for Sev 1-Critical and Sev 2-High issues:</p> <ul style="list-style-type: none"> • Continental US: 1-800-752-8061 • Europe, Middle East, Africa, and Asia Pacific: +800-AT FIBREE (+800 28 34 27 33) • For areas unable to access toll free number: +1-408-333-6061 • Toll-free numbers are available in many countries. | <p>support@brocade.com</p> <p>Please include:</p> <ul style="list-style-type: none"> • Problem summary • Serial number • Installation details • Environment description |

Brocade OEM customers

If you have purchased Brocade product support from a Brocade OEM/Solution Provider, contact your OEM/Solution Provider for all of your product support needs.

- OEM/Solution Providers are trained and certified by Brocade to support Brocade® products.
- Brocade provides backline support for issues that cannot be resolved by the OEM/Solution Provider.

- Brocade Supplemental Support augments your existing OEM support contract, providing direct access to Brocade expertise. For more information, contact Brocade or your OEM.
- For questions regarding service levels and response times, contact your OEM/Solution Provider.

Document feedback

To send feedback and report errors in the documentation you can use the feedback form posted with the document or you can e-mail the documentation team.

Quality is our first concern at Brocade and we have made every effort to ensure the accuracy and completeness of this document. However, if you find an error or an omission, or you think that a topic needs further development, we want to hear from you. You can provide feedback in two ways:

- Through the online feedback form in the HTML documents posted on www.brocade.com.
- By sending your feedback to documentation@brocade.com.

Provide the publication title, part number, and as much detail as possible, including the topic heading and page number if applicable, as well as your suggestions for improvement.

About This Document

- [Supported hardware and software](#)..... 11
- [What's new in this document](#)..... 11

Supported hardware and software

This document includes information specific to the Brocade DCX 8510-8 running Brocade Fabric OS version 7.0.0 and later.

What's new in this document

The following changes have been made:

- Added information about the newly supported FC16-64 port blade.
- Added information about the newly supported FCOE10-24 port blade.
- Updated the WWN card removal and replacement procedure.
- Updated and changed the Technical Specifications appendix to a new format that is common across all Brocade products.

What's new in this document

Brocade DCX 8510-8 Overview

- [Brocade DCX 8510-8 features](#)..... 13
- [Brocade DCX 8510-8 hardware components](#)..... 14
- [Brocade DCX 8510-8 blades](#)..... 17
- [High availability](#)..... 19
- [Reliability](#)..... 19
- [Serviceability](#)..... 20
- [Software features](#)..... 20
- [Security](#)..... 20
- [Network manageability](#)..... 21

Brocade DCX 8510-8 features

Key features of the Brocade DCX 8510-8 include:

- Up to 512 16-Gbps external ports in a single chassis , enabling high density SAN configurations with reduced footprint.
- Support for 2, 4, 8, and 16 Gbps autosensing Fibre Channel ports. Trunking technology groups up to eight ports to create high performance 128-Gbps ISL trunks between switches.
- The Brocade DCX 8510-8 also supports 10-Gbps FC-type SFPs in 32/48-port 16-Gbps port blades, and 10-GbE SFPs in the FX8-24 and FCOE10-24 application blades . The two types of SFPs are not interchangeable.
- The 10-Gbps port speed can be manually configured on any port of the 32- and 48-port 16-Gbps port blades.
- Support for many of the application, port blade, and control processor (CP) blades supported in the Brocade DCX family of backbones (with the exception of the Core Switch Blade), thereby providing flexible system configurations and fewer types of new blades.
- Beginning with Fabric OS v7.0.1, up to nine chassis can be connected with the use of 4x16 Gbps quad SFP (QSFP) inter-chassis links (ICLs). Fabric OS v7.0.0 permits up to six chassis to be linked.
- Support for high-performance port blades running at 2, 4, 8, 10, or 16-Gbps, enabling flexible system configuration.
- Redundant and hot-swappable control processor and core switch blades, power supplies, blower assemblies, and WWN cards that enable a high availability platform and enable nondisruptive software upgrades for mission-critical SAN applications.
- Universal ports that self-configure as E_Ports, F_Ports, EX_Ports and M_Ports (mirror ports). 10-Gbps ports are E_Ports only.
- Diagnostic port (D_Port) functionality.
- In-flight data cryptographic (encryption/decryption) and data compression capabilities through the 16-Gbps port blades when configured as ISLs.
- Fibre Channel over IP (FCIP) functionality through the FX8-24 blade.
- Fibre Channel over Ethernet (FCoE) capability through the FCOE10-24 blade.

Brocade DCX 8510-8 hardware components

The Brocade DCX 8510-8 features a modular and scalable mechanical construction that allows a wide range of flexibility in installation, fabric design, and maintenance. The chassis can be mounted with the cables facing the front of the equipment rack or to the rear, and consists of the following:

- Up to eight hot-swappable port blade assemblies that can be configured in a single chassis, delivering up to 512 16-Gbps Fibre Channel ports.
- Two slots for control processor blades (CP8):
 - A single active CP8 blade can control all 512 ports in the chassis.
 - The standby CP8 blade assumes control of the Brocade DCX 8510-8 if the active CP fails.
- Two slots for core switch blades (CR16-8):
 - CR16-8 blade interconnects all port blades.
 - Inter-chassis link (ICL) connectors to connect to as many as nine neighboring chassis using Fabric OS v7.0.1 or later. Only six chassis can be connected using Fabric OS v7.0.0.
 - Both CR16-8 blades are active.
- Modular, hot-swappable port blades:
 - 32-port, 8-Gbps blades (FC8-32E)
 - 48-port, 8-Gbps blades (FC8-48E)
 - 64-port, 8-Gbps blades (FC8-64)
 - 32-port, 16-Gbps blades (FC16-32)
 - 48-port, 16-Gbps blades (FC16-48)
 - 64-port, 16-Gbps blades (FC16-64)
- Modular, hot-swappable application blades:
 - FX8-24: 24-port (12 FC, 10 1-GbE, and 2 10-GbE) FCIP extension blade enabling long distance communication over existing IP infrastructure.
 - FCOE10-24: 24-port (24 10-GbE) CEE-based FCoE blade enabling enhanced connectivity using existing Ethernet infrastructure. The FCoE blade can be used in the same chassis with only the FC8-32E and FC16-32 port blades. The FCoE blade cannot be used with any other FC port or application blades in the same chassis.
- Modular, hot-swappable encryption blades:
 - FS8-18: 16-port, up to 4 blades per chassis, supporting in-flight data cryptographic (encryption/decryption) and data-compression capabilities.
- Modular, hot-swappable field-replaceable units (FRUs):
 - Three blower assemblies.
 - Up to four power supplies (100-240 VAC autosensing).
 - At 110 VAC (nominal): Four power supplies are required for high availability.
 - 220 VAC (nominal) is recommended for efficiency. Two or four power supplies are provided depending on the quantity ordered. Refer to "Power specifications" in the "Specifications" appendix for specific requirements for high availability.
 - Redundant AC primary power connections ensure high availability. Each power supply has its own connector, so the number of primary power connections is four for optimum efficiency and redundancy.
 - Two WWN cards.
 - Blades use small form-factor pluggable (SFP+, mSFP, and QSFP) optical transceivers.
 - The 8-Gbps SFP+s and mSFPs auto-negotiate at 2, 4, and 8 Gbps.
 - The 10-Gbps speeds must be manually set and require special 10-Gbps FC SFP+ transceivers.
 - The 16-Gbps SFP+ transceivers support speeds of 2, 4, 8, 10, and 16 Gbps.

- The 16-Gbps QSFPs supported on FC16-64 port blade auto-negotiate at 4, 8, and 16 Gbps.
- The 16-Gbps QSFPs based inter-chassis link (ICL) on the core blades run at 64 Gbps (four fixed 16-Gbps clustered in a single quad connector and cable).
- Blades that are serviced from the port side of the Brocade DCX 8510-8. Blowers, power supplies, and power cables that are serviced from the nonport side.
- World Wide Name (WWN) cards on the nonport side, to maintain chassis-specific information such as WWNs, IP addresses, and summary status information of each port blade and power supply through LEDs.
- Redesigned cable management comb and chassis door.

Port side of the Brocade DCX 8510-8

NOTE

Airflow in the Brocade DCX 8510-8 is from the nonport (noncable) side to the port (cable) side and out the exhaust vent.

FIGURE 1 Port side of the Brocade DCX 8510-8 (sample configuration)

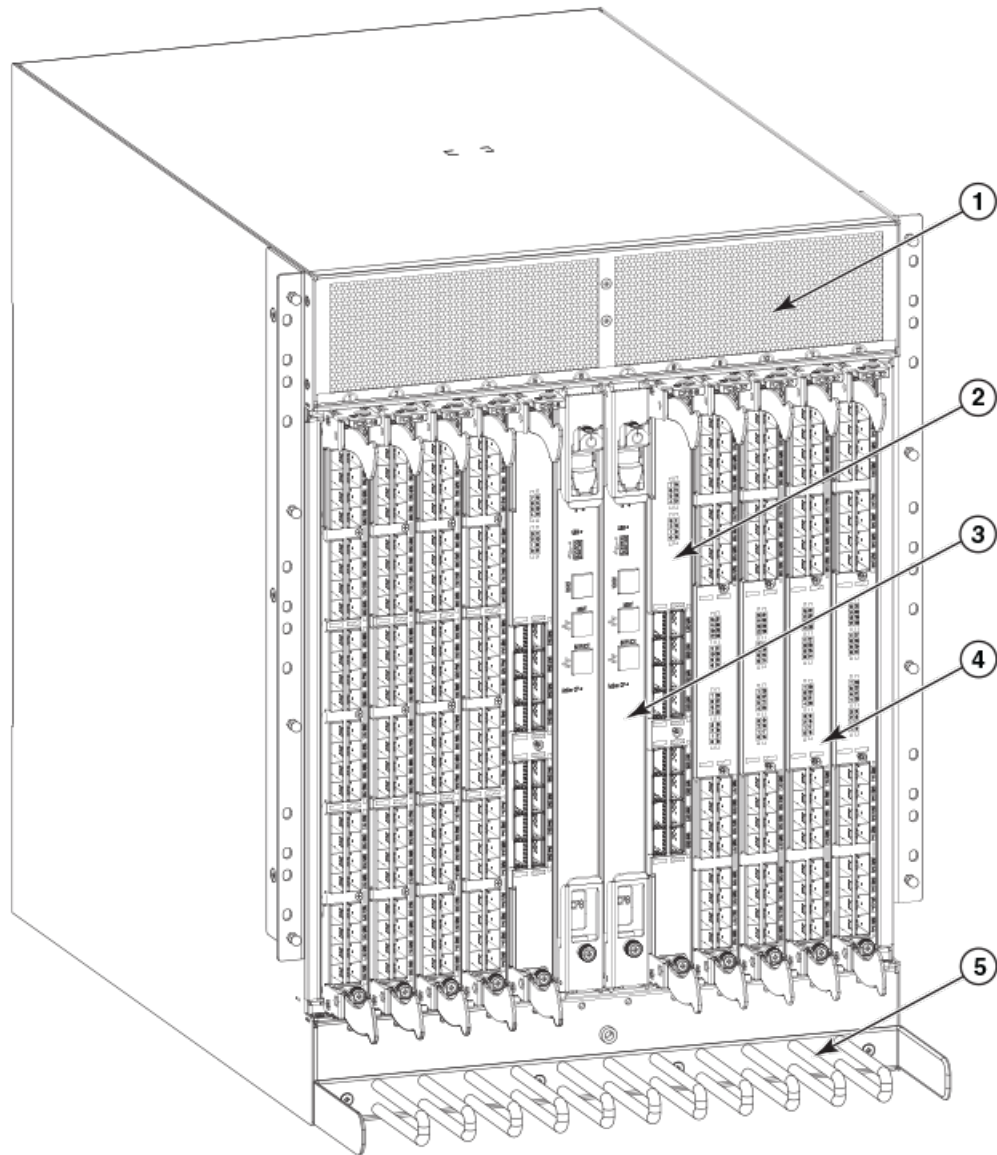

1. Exhaust vent
2. Core switch blade (CR16-8)
3. Control processor blade (CP8)
4. FC16-32 port blade
5. Cable management comb

Nonport side of the Brocade DCX 8510-8

The following figure shows a sample configuration of the nonport side view of the Brocade DCX 8510-8.

FIGURE 2 Nonport side of the Brocade DCX 8510-8 (sample configuration)

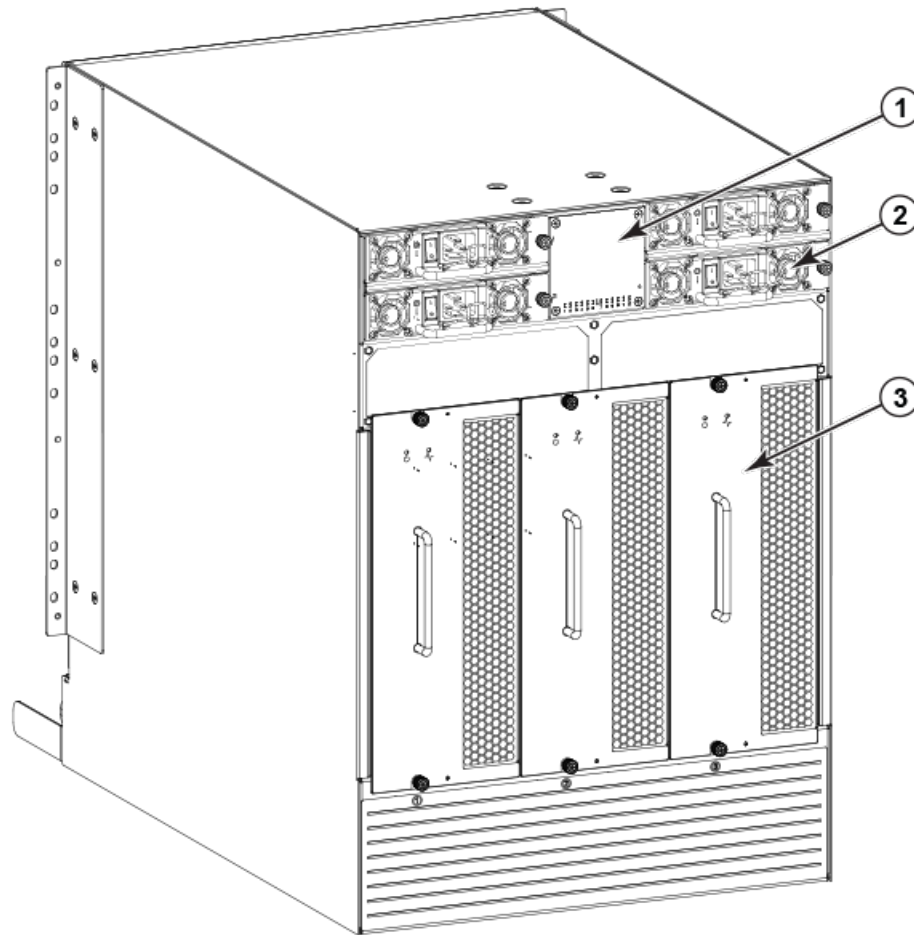

1. WWN bezel (logo plate - WWN card behind)
2. Power supply
3. Blower assembly

Brocade DCX 8510-8 blades

The following table summarizes the port, application, control processor, and core switch blades that are available for the Brocade DCX 8510-8.

TABLE 1 Blades available for the Brocade DCX 8510-8

| Description | Name | Function |
|--|------|---|
| Brocade DCX 8510-8 control processor blade | CP8 | The CP8 blade contains the control plane for the chassis. There are two CP8 blades for redundancy. This control processor blade is compatible with the Brocade DCX 8510-8, Brocade DCX 8510-4, Brocade DCX, and Brocade DCX-4S. |

TABLE 1 Blades available for the Brocade DCX 8510-8 (Continued)

| Description | Name | Function |
|--------------------------------------|-----------|--|
| Brocade DCX 8510-8 core switch blade | CR16-8 | The CR16-8 blade contains the ASICs for switching between port blades. Every port blade connects to each core switch blade. There can be up to 512 16-Gbps or 8-Gbps total ports for port blades. Each core switch blade connects to 128 backplane ports. Core switch blades have additional front port connectivity to connect multiple chassis and backplane connections for the storage server blade. This core switch blade is compatible only with the Brocade DCX 8510-8. Requires specific type of QSFP transceivers. |
| 32-port 8-Gbps port blade | FC8-32E | A 32-port Brocade port blade supporting 2, 4, and 8 Gbps Fibre Channel port speeds. This port blade is compatible with the Brocade DCX 8510-8 and Brocade DCX 8510-4. This blade requires Fabric OS v7.0.1 or later to run in this chassis. |
| 48-port 8-Gbps port blade | FC8-48E | A 48-port Brocade port blade supporting 2, 4, and 8 Gbps Fibre Channel port speeds. This port blade is compatible with the Brocade DCX 8510-8 and Brocade DCX 8510-4. This blade requires Fabric OS v7.0.1 or later to run in this chassis. |
| 64-port 8-Gbps port blade | FC8-64 | A 64-port Brocade port blade supporting 2, 4, and 8 Gbps port speeds with mSFPs. This port blade is compatible with the Brocade DCX 8510-8, Brocade DCX 8510-4, Brocade DCX, and Brocade DCX-4S. |
| 32-port 16-Gbps port blade | FC16-32 | A 32-port Brocade port blade supporting 2, 4, 8, 10, and 16 Gbps Fibre Channel port speeds. The blade also supports port-based in-flight encryption/decryption and compression/decompression. This port blade is compatible with the Brocade DCX 8510-8 and Brocade DCX 8510-4 and requires Fabric OS v7.0.0 or later to run in this chassis. |
| 48-port 16-Gbps port blade | FC16-48 | A 48-port Brocade port blade supporting 2, 4, 8, 10, and 16 Gbps Fibre Channel port speeds. The blade also supports port-based in-flight encryption/decryption and compression/decompression. This port blade is compatible with the Brocade DCX 8510-8 and Brocade DCX 8510-4 and requires Fabric OS v7.0.0 or later to run in this chassis. |
| 64-port 16-Gbps port blade | FC16-64 | A 64-port Brocade port blade supporting 4, 8, and 16-Gbps Fibre Channel port speeds. The blade also supports port-based in-flight encryption/decryption and compression/decompression. This port blade is compatible with the Brocade DCX 8510-8 and Brocade DCX 8510-4 and requires Fabric OS v7.3.0 or later to run in this chassis. Requires specific type of QSFP transceivers and those are not the same as used in the core blades. |
| Fibre Channel over Ethernet blade | FCOE10-24 | The FCOE10-24 blade enables FCoE functionality over existing Ethernet infrastructure utilizing CEE protocols. It has 24 10-GbE ports available. This FCoE application blade is compatible with the Brocade DCX, Brocade DCX-4S, and Brocade DCX 8510-8 chassis. This FCoE blade can be used in the same chassis with only the FC8-32E and FC16-32 port blades. This FCoE blade cannot be used with any other FC port blades or application blades in the same chassis. Refer to the Fabric OS Release Notes for limitations in using this blade. |
| Storage encryption blade | FS8-18 | The FS8-18 blade enables data cryptographic (encryption/decryption) and data-compression capabilities for data-at-rest. It has 16 Fibre Channel optical SFP ports. This application blade is compatible with the Brocade DCX 8510-8, Brocade DCX 8510-4, Brocade DCX, and Brocade DCX-4S and requires Fabric OS v7.0.0 or later to run in the 8510-4 and 8510-8 chassis. |

TABLE 1 Blades available for the Brocade DCX 8510-8 (Continued)

| Description | Name | Function |
|----------------------|--------|--|
| FCIP extension blade | FX8-24 | The FX8-24 blade enables FCIP functionality over existing IP infrastructure. It has 12 FC ports, 10 1-GbE ports, and two 10-GbE ports available. This application blade is compatible with the Brocade DCX 8510-8, Brocade DCX 8510-4, Brocade DCX, and Brocade DCX-4S and requires Fabric OS v7.0.0 or later to run in the DCX 8510-4 and DCX 8510-8 chassis. |

High availability

The following features contribute to the Brocade DCX 8510-8 high availability design:

- Redundant, hot-swappable FRUs, including blades, power supplies, blowers, and WWN cards
- Enhanced data integrity on all data paths
- Fabric Shortest Path First (FSPF) rerouting around failed links
- Integration with Simple Network Management Protocol (SNMP) managers
- Automatic control processor failover
- Nondisruptive "hot" software code loads and activation
- Easy configuration, save, and restore

The high availability software architecture of the Brocade DCX 8510-8 provides a common framework for all applications that reside on the system, allowing global and local states to be maintained through any component failure. High availability elements consist of the High Availability Manager, the heartbeat, the fault/health framework, the replicated database, initialization, and software upgrade.

The High Availability Manager controls access to the standby control processor, facilitates software upgrades, prevents extraneous CP failover activity, closes and flushes streams, provides flow control and message buffering, and supports a centralized active and standby state.

Reliability

The Brocade DCX 8510-8 uses the following error detection and correction mechanisms to ensure reliability of data:

- Error Detection and Correction over main control processor memory.
- Error Detection and Correction mechanism, which checks for encoder errors and fault isolation (EDFI), such as cyclic redundancy checking (CRC), parity checking, checksum, and illegal address checking.
- Power-on self-test (POST).
- Dual control processors that enable hot, nondisruptive fast firmware upgrades.
- One serial port and two Ethernet ports (on each control processor) for management and for service. Offline control processor diagnostics and remote diagnostics simplify troubleshooting. The standby control processor monitors diagnostics to ensure the system is operational should a failover be necessary.
- Bus monitoring and control of blades and other field-replaceable units (FRUs).

Serviceability

The Brocade DCX 8510-8 provides the following features to enhance and ensure serviceability:

- Modular design with hot-swappable components.
- Flash memory that stores two firmware images per control processor.
- USB port on control processor blades for most tasks that formerly required an FTP/SCP server, including software and firmware upgrades.
- Nonvolatile random-access memory (NVRAM), containing the OEM serial number, Brocade serial number, revision information, and part number information.
- Background health-check daemon.
- Memory scrubber, self test, and bus ping to determine if a bus is not functioning.
- RASlog messages.
- SMI-S compliant.
- Hardware and software watchdog timers.
- Status LEDs.
- Predictive diagnostics analysis through Fabric Watch.
- SNMP (including version 3) integration with higher-layer managers.

Software features

The Fabric OS allows any Fibre Channel-compliant device to attach to the switches as long as it conforms to the device login, name service, and related Fibre Channel standards. Each operating environment requires that a Fibre Channel host bus adapter (HBA) be available with a standards-compliant driver for correct interface to the fabric.

Fabric OS consists of a set of embedded applications running on top of an embedded Linux operating system kernel. Some of these applications include:

- Name server
- Alias server
- Zone server
- Simple Network Management Protocol (SNMP) agent
- SMI-S compliant API
- Syslog auditing
- Reliable Commit Service (RCS)
- NTP
- Tasks to manage address assignment, routing, link initialization, fabric initialization, link shutdown, Brocade DCX 8510-8 shutdown, and the user interface

Security

The following list highlights some of the key security features available for the Brocade DCX 8510-8 and for other Brocade enterprise-class products running Fabric OS 7.0.1 or later. For details, contact your Brocade DCX 8510-8 supplier and refer to the Brocade White Paper, "The Growing Need for Security in Storage Area Networks."

- DH-CHAP
- SSHv2 (using AES, 3DES, RSA)
- HTTPS (using AES)
- SNMPv3
- FC-SP
- Secure RPC
- Secure file copy (SCP)
- Telnet disable
- Telnet timeout
- IP filters (block listeners)
- Secure passwords (centralized control through RADIUS/CHAP)
- Multiple user accounts (MUAs) (Up to 255)
- Role-based access controls (RBACs)
- Administrative domains/Virtual fabrics
- Boot PROM password reset
- Password hardening policies
- Up front login in Web Tools
- Login banner
- Monitoring of attempted security breaches (through audit logging)
- Monitoring of attempted security breaches (through Fabric Watch Security Class)
- Fibre Channel security policies: DCC and SCC
- Trusted Switch (FCS) for central security management
- Management access controls (SNMPv3, Telnet, FTP, serial port, front panel)
- Hardware-enforced zoning by WWN, domain/port ID, or both
- Default zoning
- RSCN suppression and aggregation
- Configurable RSCN suppression by port
- NTPv3 (to synchronize timestamps)
- Event auditing
- Change tracking
- Firmware change alerts in Fabric Manager
- Persistent port disable
- Persistent domain ID
- E_Port disable

Network manageability

The Brocade DCX 8510-8 has a single domain and is managed as a single element with Brocade Network Advisor. The Brocade DCX 8510-8 responds to its own IP address and appears as a separate entity to the Telnet protocol and SNMP.

All management interfaces, such as Telnet, Web Tools, standards-compliant SMI-S, and Management Server, support a "port N within blade M" naming scheme.

The Brocade DCX 8510-8 supports SNMPv1 and SNMPv3. When SNMP devices send SNMP messages to a management console running SAN management software, the information is stored in a management information base (MIB). Fabric OS v7.0.0 and later supports the latest Fibre Alliance Fibre Channel Management (FCMGMT) and Storage Management Initiative (SMI) MIBs, which allow common information necessary for management software to provide information to a SAN administrator. Refer to the *Fabric OS MIB Reference* for additional MIB information.

Installation of the Brocade DCX 8510-8

- Time and items required..... 23
- Preparing for the Brocade DCX 8510-8 installation..... 24
- Unpacking and installing the Brocade DCX 8510-8..... 25
- Items included with the Brocade DCX 8510-8..... 26
- Providing power to the Brocade DCX 8510-8 Backbone..... 27
- Port numbering..... 27
- Chassis slots..... 29
- Cable management..... 29

Time and items required

You can set up and install the Brocade DCX 8510-8 in the following ways:

- As a standalone unit on a flat surface.
- In a 19-inch Electronic Industries Association (EIA) cabinet, using the 14U Rack Mount Kit (provided).
- In a mid-mount telecommunications (Telco) rack, using the Mid-Mount Rack Kit available from your Brocade DCX 8510-8 supplier.

This chapter describes how to set up the Brocade DCX 8510-8 as a standalone unit. For rack-mount installation instructions, refer to the appropriate manual as described in the following table.

The following table describes the main installation and setup tasks, the estimated time required for each, and the items required to complete the task based on a fully populated Brocade DCX 8510-8 (512 Fibre Channel ports using the FC16-64 port blades). Configurations with fewer ports require less time. These time estimates assume a prepared installation site and appropriate power and network connectivity.

TABLE 2 Installation tasks, time, and items required

| Installation task | Time estimate | Items required |
|---|---------------|---|
| Site preparation and unpacking Brocade DCX 8510-8 | 30 minutes | 1/2-in. socket wrench (to remove pallet bolts). #2 Phillips screwdriver(for cable management comb). Pallet jack. Hydraulic lift or assisted lift, able to raise to a minimum of 140 cm (55 in.), with a minimum capacity of 115 kg (254 lb). The Brocade DCX 8510-8 weighs 161.2 kg (355 lb) with eight FC16-64 port blades installed (512 ports). |
| Installing rack mount kit | 30 minutes | Refer to the <i>14U Rack Mount Kit Installation Procedure</i> or the <i>Mid-Mount Rack Kit Installation Procedure</i> . |
| Mounting and securing Brocade DCX 8510-8 in rack | 30 minutes | |

TABLE 2 Installation tasks, time, and items required (Continued)

| Installation task | Time estimate | Items required |
|--|--|---|
| Installing power cables and powering on the Brocade DCX 8510-8 | 20 minutes | Power cables (provided in the Brocade DCX 8510-8 accessory kit). |
| Establishing serial connection, logging in to Brocade DCX 8510-8, and configuring IP addresses | 20 minutes | Serial cable (provided in the accessory kit). Workstation computer with a serial port or terminal server port and a terminal emulator application (such as HyperTerminal). Ethernet IP addresses for the Brocade DCX 8510-8 chassis and for both control processor blades: total three addresses. |
| Installing an Ethernet cable, opening a Telnet session, and configuring the Brocade DCX 8510-8 domain ID, date and time, and additional system parameters. Verify and back up configuration. | 20 minutes | Ethernet cabling (optional) for Telnet access. Refer to the <i>Fabric OS Administrator's Guide</i> . |
| Installing transceivers as needed | 30 minutes (longer if using high-density port blades) | SFP+, mSFP, and QSFP optical transceivers as needed. |
| Attaching fiber-optic cables, cable ties, and cable guides | 2-3 hours | Fiber-optic cables, cable ties, and cable management comb. |

Preparing for the Brocade DCX 8510-8 installation

NOTE

Read the [Caution and Danger Notices](#) before installation. Read "[Power specifications](#)" to plan for meeting power supply standards before installing the chassis. Read [Cable management](#) on page 29 to plan for cable management.

The following steps are required to ensure correct installation and operation.

1. Provide a space that is 14 rack units (14U) high, 61.29 cm (24.09 in.) deep, and 43.74 cm (17.22 in.) wide. 1U is equal to 4.45 cm (1.75 in.).

Plan to install the Brocade DCX 8510-8 with the nonport side facing the air-intake aisle. The Brocade DCX 8510-8 can be installed facing either direction, if serviceability and cooling requirements are met.

2. Ensure that dedicated electrical branch circuits with the following characteristics are available:

NOTE

Refer to "[Power specifications](#)" for specific requirements depending on your chassis configuration.

- 200 - 240 VAC, 50-60 Hz (two branch circuits) - recommended for high availability and maximum blade usage when configured with 192 16 Gbps ports (four circuits required for high availability if configured with 384 16 Gbps ports)
- 110 - 120 VAC, 50-60 Hz (four branch circuits highly recommended)
- Two or four cables for 200 - 240 VAC service; up to four cables for 110 - 120 VAC service
- Protected by a circuit breaker in accordance with local electrical codes
- Supply circuit, line fusing, and wire size adequate to the electrical rating on the chassis nameplate
- Location close to the chassis and easily accessible
- Grounded outlets installed by a licensed electrician and compatible with the power cords

**CAUTION**

Use a separate branch circuit for each power cord, which provides redundancy in case one of the circuits fails.

3. Plan for cable management before installing the chassis.

Cables can be managed in a variety of ways, such as by routing cables below the chassis, to either side of the chassis, through cable channels on the sides of the cabinet, or by using patch panels.

4. Ensure that the following is available for configuration of the Brocade DCX 8510-8:
 - Workstation with an installed terminal emulator, such as HyperTerminal
 - Serial cable (provided)
 - Three Ethernet cables (including one spare)
 - Access to an FTP server for backing up the switch configuration or collecting **supportsave** output data (optional)
 - A Brocade USB stick for collecting **supportsave** output data (optional)
 - Transceivers (copper and optical) and compatible cables
5. Ensure that the air intake and exhaust vents have a minimum of 5.1 cm (2 in.) of airspace.
6. Ensure that the air temperature on the air intake side is less than 40°C (104°F) during operation.

Unpacking and installing the Brocade DCX 8510-8

Use the following procedure to unpack and install your Brocade DCX 8510-8.

**DANGER**

A fully populated Brocade DCX 8510-8 (eight FC16-64 port cards, 512 ports) weighs approximately 161.2 kg (355 lbs) and requires a hydraulic or assisted lift to install it.

1. Unpack the Brocade DCX 8510-8.
 - a) Cut the bands that encircle the packaging.
 - b) Remove the lid and the kits and foam from the top of the chassis.
 - c) Lift the cardboard box off the chassis and remove the plastic bag from around the chassis. Save the packing materials for use when returning the old chassis.
 - d) Leave the chassis on top of the plastic shipping tray if the chassis must be transported to the installation location.

NOTE

The Brocade DCX 8510-8 packaging does not incorporate a wood pallet and pallet brackets. The chassis sits on top of a plastic shipping tray.

2. Use a pallet jack or other assisted lift to transport the new chassis to the installation area. Doorways must be wider than 36 in. (91 cm) to accommodate the chassis.
3. Remove the 14U Rack Mount Kit, accessory kit, packing foam, and antistatic plastic from the chassis and set aside.
4. Remove the chassis door from the Brocade DCX 8510-8.
5. Remove the cable management comb.
6. Use a lift to raise the chassis to the correct level. If installing the chassis in a cabinet, follow the instructions provided by the rack kit manufacturer.
7. If applicable, lock the wheels of the lift.
8. Gently slide the chassis onto the final installation surface, ensuring that it remains supported during the transfer.
9. Ensure that the chassis is oriented so that the nonport side has access to intake air (cool).
10. Reinstall the cable management comb.
11. Reinstall the door. The door must be installed to meet EMI compliance.

Items included with the Brocade DCX 8510-8

The Brocade DCX 8510-8 ships with the following:

- Brocade DCX 8510-8 chassis, populated with:
 - Control processor blades (CP8)
 - Core switch blades (CR16-8)
 - Port blades, application blades, and encryption blades (included based on customer specification)
 - Blade slot filler panels (for slots not filled by blades)
 - WWN cards
 - WWN bezel (logo plate)
 - Power supplies
 - Power supply filler panel (included if there are fewer than four power supplies)
 - Blower assemblies
 - Cable management comb
 - Chassis door
- Accessory kit containing the following items:
 - *Brocade DCX 8510-8 Backbone QuickStart Guide*
 - ESD grounding strap
 - USB device
 - RS-232 serial cable. The RS-232 cable has an adapter at one end that can be removed to provide an RJ-45-style connector.
- 14U Rack Mount Kit with instructions (includes rear brackets and bottom support rails)

Order the Brocade-branded optical transceivers (SFP+, mSFP, and QSFP). The Brocade DCX 8510-8 supports SWL, LWL, and ELWL transceivers. The mSFPs and QSFPs are SWL transceivers only.

NOTE

For information about the SFP+, mSFP, and QSFP transceivers that are qualified for the Brocade DCX 8510-8, go to <http://www.brocade.com/downloads/documents/matrices/sfp-matrix-mx.pdf>.

Providing power to the Brocade DCX 8510-8 Backbone

For this procedure, refer to "[Power specifications](#)" for power supply requirements for your chassis.

Complete the following steps to provide power to the chassis.



DANGER

Make sure that the power source circuits are properly grounded, then use the power cord supplied with the device to connect it to the power source.

1. Connect the AC power cords to the power supply assemblies. Two or four power cords are required depending on electrical service and if the high availability option is selected.
2. Connect the power cords to a power source with voltage of 200 to 240 VAC, 47 to 63 Hz (normally two power cords or as many as four) or optionally to a power source with voltage of 110 to 120 VAC, 47 to 63 Hz (up to four power cords).

NOTE

Use of the high-voltage line (200 to 240 VAC) is highly recommended because of better power-conversion efficiency. A DCX 8510-8 chassis fully loaded with 16 Gbps port blades (512 ports total) should be supplied with four power supplies connected to 200-240 VAC lines.

3. Switch the AC power switches on the power supplies to I. The AC power switches light green when switched on and power is supplied.

The Brocade DCX 8510-8 performs a power-on self-test (POST) each time it is powered on. POST takes approximately 10 minutes and is complete when the indicator light activity displays the operational state. You can bypass POST by using the **fastBoot** command. You can also disable POST for successive reboots on the Brocade DCX 8510-8 using the **diagDisablePost** command.

NOTE

Do not connect the switch to the network until the IP addresses are configured.

For information about LED patterns, refer to [Monitoring System Components](#) on page 49.

Port numbering

The Brocade DCX 8510-8 uses the following port numbering method ([Port Numbering Template](#) on page 137"):

| Blade | Port numbering | Trunking port groups |
|--------------------|--|---|
| FC8-32E port blade | <ul style="list-style-type: none"> 0 through 15 from bottom to top on the left set of ports. 16 through 31 from bottom to top on the right set of ports. | <ul style="list-style-type: none"> 0-7, 8-15, 16-23, and 24-31 |
| FC8-48E port blade | <ul style="list-style-type: none"> 0 through 23 from bottom to top on the left set of ports 24 through 47 from bottom to top on the right set of ports. | <ul style="list-style-type: none"> 0-7, 8-15, 16-23, 24-31, 32-39, and 40-47 |
| FC8-64 port blade | <ul style="list-style-type: none"> 0 through 31 from bottom to top on the left set of ports. 32 through 63 from bottom to top on the right set of ports. | <ul style="list-style-type: none"> 0-7, 8-15, 16-23, 24-31, 32-39, 40-47, 48-55, and 56-63*. <p>(* - Octet 56-63 E_Port trunks are permitted on the logical or base switch only.)</p> |
| FC16-32 port blade | <ul style="list-style-type: none"> 0 through 15 from bottom to top on the left set of ports. 16 through 31 from bottom to top on the right set of ports. | <ul style="list-style-type: none"> 0-7, 8-15, 16-23, and 24-31. |
| FC16-48 port blade | <ul style="list-style-type: none"> 0 through 23 from bottom to top on the left set of ports. 24 through 47 from bottom to top on the right set of ports. | <ul style="list-style-type: none"> 0-7, 8-15, 16-23, 24-31, 32-39, and 40-47. |
| FC16-64 port blade | <ul style="list-style-type: none"> 0 through 63 from bottom to top. <p>These are QSFP ports 0-15. For supported QSFPs, refer to Qualified transceivers for the FC16-64 port blade and the core blades on page 44</p> | <ul style="list-style-type: none"> 0-7, 8-15, 16-23, 24-31, 32-39, 40-47, 48-55, and 56-63. |
| FCOE10-24 blade | <ul style="list-style-type: none"> 0 through 23 in two vertical rows from bottom left to top right. | <ul style="list-style-type: none"> NA |
| CR16-8 core blade | <p>ICL connectors are numbered from:</p> <ul style="list-style-type: none"> 0 through 7 from bottom to top on the left set of ports. 8 through 15 from bottom to top on the right set of ports. <p>Each connector is a group of four 16-Gbps ports. For supported QSFPs, refer to Qualified transceivers for the FC16-64 port blade and the core blades on page 44</p> | <ul style="list-style-type: none"> Trunk group 0: QSFP ports 0-3 and 8-11. Trunk group 1: QSFP ports 4-7 and 12-15. <p>NOTE Individual FC ports within the same QSFP port cannot form a trunk. A trunk has to comprise of individual FC ports from different QSFP ports.</p> |
| FS8-18 blade | <ul style="list-style-type: none"> The 16 physical Fibre Channel ports on this blade are numbered 0 through 15 from bottom to top . The two 10/100/1000 BaseT ports are numbered from the bottom as GE0 and GE1. | <ul style="list-style-type: none"> 0-7 and 8-15 |

| Blade | Port numbering | Trunking port groups |
|--------------|--|---|
| FX8-24 blade | Ports are numbered in groups: <ul style="list-style-type: none"> The FC ports are numbered from 0 through 11 in two vertical columns of six ports starting from the bottom left and bottom right in the lower group of 12 ports. They are labeled FC on the front panel diagram. The two 10-GbE ports are 0 and 1 and are in the left column just above the FC ports. They are labeled 10GE on the front panel diagram. The 1-GbE ports are numbered 0 through 9 and are in both columns above the FC and 10GE ports. They are labeled GE on the front panel diagram. | Up to three FC trunking groups are permitted. The three groups are defined as follows: <ul style="list-style-type: none"> Trunk group 0: FC ports 0, 1 Trunk group 1: FC ports 6, 7 Trunk group 2: FC ports 2, 3, 4, 5, 8, 9, 10, 11 |

Chassis slots

Chassis slots are numbered 1 through 12, from left to right when facing the port side of the Brocade DCX 8510-8. Control processor blades (CP8) can be installed only in slots 6 and 7. Core switch blades (CR16-8) can be installed only in slots 5 and 8. The rest of the slots, 1-4 and 9-12, can be filled with port, application, or encryption blades. Unused slots must be filled with blade filler panels to maintain adequate cooling.

Cable management

The cable management comb ([Port side of the Brocade DCX 8510-8](#) on page 15) is attached to the chassis under the chassis door and allows for simple cable management. The comb can be installed without service disruption.

NOTE

The minimum radius to which a 50 micron cable can be bent under full tensile load is 5.1 cm (2 in.). For a cable under no tensile load, that minimum is 3.0 cm (1.2 in.).

Cables can be organized and managed in a variety of ways, for example, using cable channels on the sides of the cabinet or patch panels to minimize cable management. Following is a list of recommendations:

NOTE

You should not use tie wraps with optical cables because they are easily overtightened and can damage the optic fibers.



CAUTION

Before plugging a cable into to any port, be sure to discharge the voltage stored on the cable by touching the electrical contacts to ground surface.

- Plan for rack space required for cable management before installing the switch.
- Leave at least 1 m (3.28 ft) of slack for each port cable. This provides room to remove and replace the switch, allows for inadvertent movement of the rack, and helps prevent the cables from being bent to less than the minimum bend radius.
- If you are using Brocade ISL Trunking, consider grouping cables by trunking groups. The cables used in trunking groups must meet specific requirements, as described in the *Fabric OS Administrator's Guide* .
- For easier maintenance, label the fiber-optic cables and record the devices to which they are connected.
- Keep LEDs visible by routing port cables and other cables away from the LEDs.
- Use Velcro[®] type straps to secure and organize fiber-optic cables.

NOTE

Do not route the cables in front of the air exhaust vent, which is located at the top of the port side of the chassis.

High-density cabling

The FC8-64 high density port blade cannot use the standard LC cables because the pitch between optics in the new mini-SFP (mSFP) transceiver is smaller than in standard SFPs. Patch cables and panels can be used to attach standard size cabling to the blade if necessary. The following figure illustrates the mSFP to SFP patch cable. Refer to "Best Practices Guide: High Density Cable Management Solutions" (available at <http://www.brocade.com>) for cable management guidelines for high-density port solutions, and cable and patch panel part numbers.

FIGURE 3 Cable design for the mSFP patch cables for the FC8-64 high density port blade

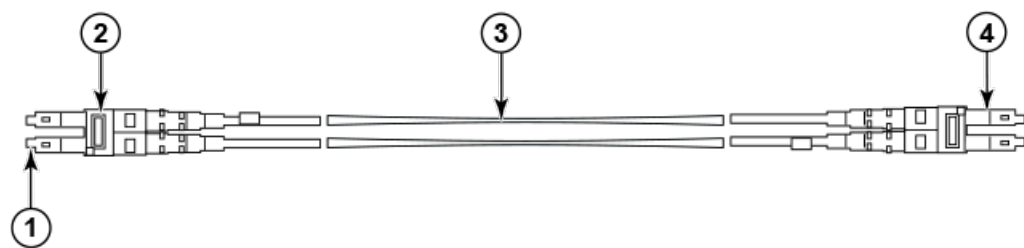

1. mSFP connector
2. Duplex clip (black)
3. 6 mm cable
4. SFP connector

Note that the duplex clip on the mSFP end of the cable is black for easier recognition. Refer to [Qualified cables for the FC8-64 port blade](#) on page 31 for a listing of the qualified mSFP optical cables for the FC8-64 port blade.

If ISL Trunking is in use, group the cables by trunking group. The ports are color-coded to indicate which ports can be used in the same ISL Trunking group: eight ports marked with solid black ovals alternate with eight ports marked with oval outlines.

Qualified cables for the FC8-64 port blade

The following table lists the third party cables that have been qualified for use with the mSFP transceivers in the FC8-64 high density port blade.

TABLE 3 Qualified cables for mSFP connections for the FC8-64 high density port blade

| Description | Length | Corning part number | Molex part number | Amphenol part number |
|--|--------|--------------------------------|-------------------|---------------------------------|
| Patch cables - mSFP to LC | | S50502S5120XXXM (XXX = length) | | 943-99865-1XXXX (XXXX = length) |
| mSFP LC - standard LC, duplex, multi-mode, OM3, 50/125 | 1 m | S50502S5120001M | 106273-0525 | 943-99865-10001 |
| mSFP LC - standard LC, duplex, multi-mode, OM3, 50/125 | 2 m | S50502S5120002M | 106273-0526 | 943-99865-10002 |
| mSFP LC - standard LC, duplex, multi-mode, OM3, 50/125 | 3 m | S50502S5120003M | 106273-0527 | 943-99865-10003 |
| mSFP LC - standard LC, duplex, multi-mode, OM3, 50/125 | 5 m | S50502S5120005M | 106273-0528 | 943-99865-10005 |
| mSFP LC - standard LC, duplex, multi-mode, OM3, 50/125 | 10 m | S50502S5120010M | 106273-0529 | 943-99865-10010 |
| Patch cables - mSFP to mSFP | | S5S502S5120XXXM (XXX = length) | | 943-99866-1XXXX (XXXX = length) |
| mSFP LC - mSFP LC, duplex, multi-mode, OM3, 50/125 | 1 m | S5S502S5120001M | 106273-0560 | 943-99866-10001 |
| mSFP LC - mSFP LC, duplex, multi-mode, OM3, 50/125 | 2 m | S5S502S5120002M | 106273-0561 | 943-99866-10002 |
| mSFP LC - mSFP LC, duplex, multi-mode, OM3, 50/125 | 3 m | S5S502S5120003M | 106273-0562 | 943-99866-10003 |
| mSFP LC - mSFP LC, duplex, multi-mode, OM3, 50/125 | 5 m | S5S502S5120005M | 106273-0563 | 943-99866-10005 |
| mSFP LC - mSFP LC, duplex, multi-mode, OM3, 50/125 | 10 m | S5S502S5120010M | 106273-0564 | 943-99866-10010 |
| Trunk cables - mSFP to MTP | | tbd | | |

TABLE 3 Qualified cables for mSFP connections for the FC8-64 high density port blade (Continued)

| Description | Length | Corning part number | Molex part number | Amphenol part number |
|---|--------|-------------------------------------|-------------------|------------------------------------|
| mSFP LC - MTP-female, 12 fiber, 12" breakout, OM3, 50/125 | | H93S5TE9-BMU-XXXM (XXX = length) | | 943-99867-1XXXX (XXXX = length) |
| mSFP LC - MTP-female, 12 fiber, 6" breakout, OM3, 50/125 | 2m | | 106272-0327 | |
| mSFP LC - MTP-female, 24 fiber, 12" breakout, OM3, 50/125 | 2m | | 106272-0328 | |
| Bag of clips (quantity 64) | | TRIGGER-BP-NP | n/a | n/a |

Cable types supported on the FC16-64 port blade

The FC16-64 port blade supports simplified cable management using QSFP cables. Each QSFP cable has four links internally that run at 16-Gbps speed and the cables come in specific predetermined fixed lengths.

The FC16-64 port blade supports the following types of cables:

FIGURE 4 QSFP to QSFP standard cables

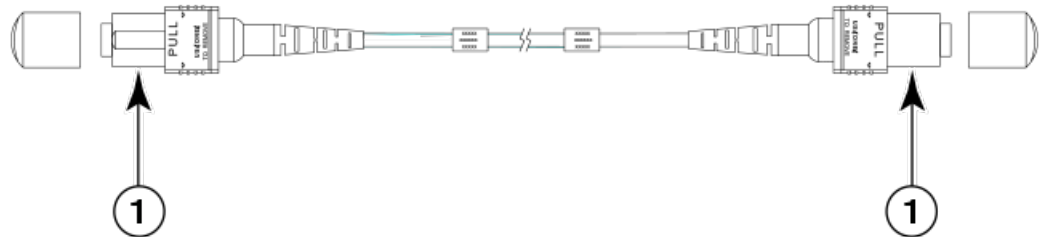

1. QSFP MTP connector

FIGURE 5 QSFP-SFP/LC Break-out/Split-out cables

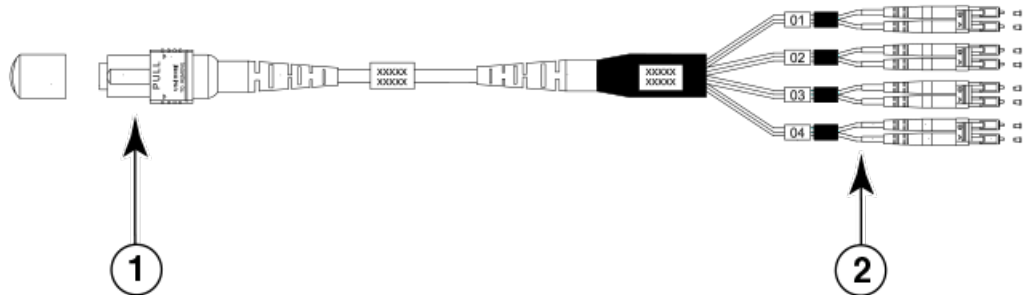

1. QSFP MTP connector
2. SFP+ LC connectors

With the support for breakout cables, each port can be in a different mode. Inside the single physical QSFP port, individual ports can be configured as an E_Port, F_Port or EX_Port. Also, each internal port inside a single physical QSFP can be part of different Logical Switches.

With the support for breakout cables, trunking can be enabled on ports in a QSFP port group, with ports connected through breakout cables at the other end.

Installing ICL cables

Refer to [Inter-chassis link \(ICL\) cable removal and replacement](#) on page 108 for the procedure to install the ICL QSFP cables.

Logging In and Configuring the Brocade DCX 8510-8

| | |
|---|----|
| • Configuring the Brocade DCX 8510-8..... | 35 |
| • Establishing a serial connection to the Brocade DCX 8510-8..... | 36 |
| • Logging in to the serial console port..... | 37 |
| • Configuring the IP addresses..... | 38 |
| • Logging off the serial console port and disconnecting the serial cable..... | 39 |
| • Establishing an Ethernet connection to the Brocade DCX 8510-8..... | 39 |
| • Customizing a switch name..... | 40 |
| • Customizing a chassis name..... | 40 |
| • Setting the domain ID..... | 40 |
| • Setting the date and time..... | 41 |
| • Verifying the PID mode..... | 43 |
| • Determining installed software licenses..... | 43 |
| • Installing transceivers and attaching cables..... | 43 |
| • Managing cables..... | 46 |
| • Verifying correct operation and backing up the configuration..... | 47 |
| • Powering off the Brocade DCX 8510-8..... | 48 |

Configuring the Brocade DCX 8510-8

The Brocade DCX 8510-8 must be configured before it is connected to the fabric, and all of the configuration commands must be entered through the active CP blade. The Brocade DCX 8510-8 configuration includes the following parameters:

- IP address and subnet mask for the chassis
- IP addresses, host names, subnet masks, and gateway addresses for both CP blades
- Switch name
- Domain ID for the Brocade DCX 8510-8 (optional)
- WWN for the Brocade DCX 8510-8

The Brocade DCX 8510-8 WWN is initially set by the factory to match the license ID (which is based on the chassis serial number). The WWN can be changed but the license ID cannot be modified.

The configuration information is mirrored to the standby CP blade, which allows the current configuration to remain available even if the active CP blade fails. The configuration information for the Brocade DCX 8510-8 is stored in the WWN cards and the flash memory of the CP blades. The configuration can be backed up to a workstation (uploaded) and then downloaded to the active CP blade if necessary.

NOTE

If the Brocade FS8-18 encryption blade is installed, refer to the *Fabric OS Encryption Administrator's Guide* for the procedures to configure the encryption functions.

The following figure illustrates the flow of the basic configuration tasks.

FIGURE 6 Configuration tasks

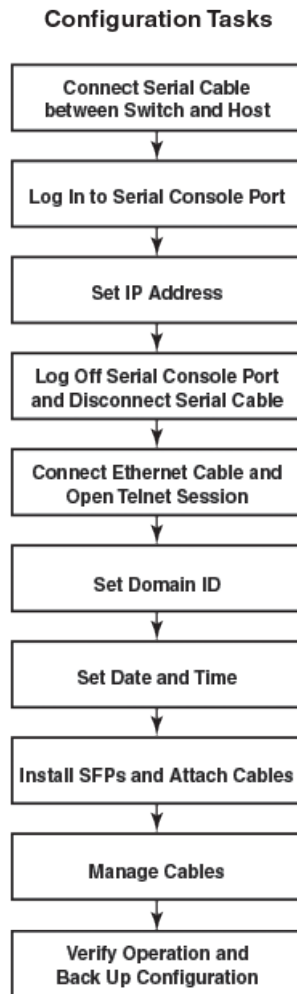

Establishing a serial connection to the Brocade DCX 8510-8

To establish a serial connection to the console port on the Brocade DCX 8510-8, complete the following steps.

1. Verify that the Brocade DCX 8510-8 is powered on and that POST is complete by verifying that all power LED indicators on the port, control processor, and core switch blades display a steady green light.
2. Remove the shipping cap from the CONSOLE port on the active CP. Use the serial cable provided with the Brocade DCX 8510-8 to connect the CONSOLE port on the active CP to a computer workstation. The active CP blade is indicated by an illuminated (blue) LED.

NOTE

The CONSOLE port is intended primarily for the initial setting of the IP address and for service purposes.

3. Access the Brocade DCX 8510-8 using a terminal emulator application (such as HyperTerminal in a Windows environment or tip in a UNIX environment).
4. Disable any serial communication programs running on the workstation (such as synchronization programs).
5. Open a terminal emulator application (such as HyperTerminal on a PC, or term, tip, or kermit in a UNIX environment), and configure the application as follows:

- In a Windows environment:

| Parameter | Value |
|-----------------|-------|
| Bits per second | 9600 |
| Data bits | 8 |
| Parity | None |
| Stop bits | 1 |
| Flow control | None |

- In a UNIX environment, enter the following string at the prompt:

```
tip /dev/ttyb -9600
```

If ttyb is already in use, use ttya instead and enter the following string at the prompt:

```
tip /dev/ttya -9600
```

When the terminal emulator application stops reporting information, press **Enter**. You receive the following login prompt:

```
CP0 Console Login:
```

6. Proceed to the next task.

Logging in to the serial console port

To log in to the Brocade DCX 8510-8 through the serial connection, follow these steps.

1. Log in to the Brocade DCX 8510-8 as **admin**. The default password is *password*. At the initial login, you are prompted to enter new admin and user passwords. Make sure to write down the new passwords and keep this information in a secure location.

```
Fabric OS (swDir)
```

```
swDir login: admin
```

```
Password:
```

```
Please change your passwords now.
```

```
Use Control-C to exit or press 'Enter' key to proceed.
```

```
swDir:admin>
```

2. (Optional) Modify passwords. To skip modifying the password, press **Ctrl+C**. For more information on passwords, refer to the *Fabric OS Administrator's Guide*.

NOTE

Passwords can be 8 to 40 characters long. They must begin with an alphabetic character. They can include numeric characters, the period (.), and the underscore (_) only. Passwords are case-sensitive, and they are not displayed when you enter them on the command line. For more information on passwords, refer to the *Fabric OS Administrator's Guide*.

Configuring the IP addresses

The Brocade DCX 8510-8 requires three IP addresses, which are configured using the **ipAddrSet** command. IP addresses are required for both CP blades (CP0 and CP1) and for the chassis management IP (shown as SWITCH under the **ipAddrShow** command) in the Brocade DCX 8510-8.

NOTE

The default IP addresses and host names for the Brocade DCX 8510-8 are:

- 10.77.77.75 / CP0 (the CP blade in slot 6 at the time of configuration)
 - 10.77.77.74 / CP1 (the CP blade in slot 7 at the time of configuration)
-

NOTE

Resetting an IP address while the Brocade DCX 8510-8 has active IP traffic or has management and monitoring tools running, such as DCFM, Fabric Watch, and SNMP, can cause traffic to be interrupted or stopped.

Complete the following steps to set the IP addresses for the Brocade DCX 8510-8.

1. Log in to the active CP as admin using the serial cable connection.
2. Set up the Brocade DCX 8510-8 IP address by entering the **ipaddrset -chassis** command:

```
swDir:admin> ipAddrSet -chassis
```

Enter the information at the prompts. Specify the **-chassis** IP address. The **-sw 0** IP address is not valid on this chassis.

NOTE

The addresses 10.0.0.0 through 10.0.0.255 are reserved and used internally by the Brocade DCX 8510-8. External IPs must not use these addresses.

3. Set up the CP0 IP address by entering the **ipaddrset -cp 0** command:

```
swDir:admin> ipAddrSet -cp 0
```

Enter the information at the prompts.

4. Set up the CP1 IP address by entering the **ipaddrset -cp 1** command:

```
swDir:admin> ipAddrSet -cp 1
```

Enter the information at the prompts.

This is a sample IP configuration:

```
swDir:admin> ipaddrset -chassis
Ethernet IP Address [0.0.0.0]: 192.168.1.1
Ethernet Subnetmask [0.0.0.0]: 255.255.255.0
Fibre Channel IP Address [0.0.0.0]:
Fibre Channel Subnetmask [0.0.0.0]:
Issuing gratuitous ARP...Done.
Committing configuration...Done.

swDir:admin>
ipaddrset -cp 0
Host Name [cp0]:
Ethernet IP Address [10.77.77.75]: 192.168.1.2
Ethernet Subnetmask [0.0.0.0
]: 255.255.255.0
Gateway IP Address [0.0.0.0
]: 192.168.1.254
IP address is being changed...Done.
Committing configuration...Done.
swDir:admin> ipaddrset -cp 1
Host Name [cp1]:
Ethernet IP Address [10.77.77.74]: 192.168.1.3
Ethernet Subnetmask [0.0.0.0]: 255.255.255.0
Gateway IP Address [0.0.0.0]: 192.168.1.254
IP address of remote CP is being changed...Done.
Committing configuration...Done.
```

Logging off the serial console port and disconnecting the serial cable

You can use the serial port to monitor error messages through the serial connection. If the serial port is no longer required, use the **logout** command to log out of the serial console, remove the serial cable, and replace the plug in the serial port.

Establishing an Ethernet connection to the Brocade DCX 8510-8

After using a serial connection to configure the IP addresses for the Brocade DCX 8510-8, you can connect the active CP blade to the local area network (LAN).

NOTE

Connecting the CP blades to a private network or VLAN is recommended.

By establishing an Ethernet connection, you can complete the Brocade DCX 8510-8 configuration using a serial session, Telnet, or management applications, such as Web Tools or Brocade Network Advisor.

Perform the following steps to establish an Ethernet connection to the Brocade DCX 8510-8.

1. Remove the shipping plug from the Ethernet port on the active CP blade.
2. Insert one end of an Ethernet cable into the Ethernet port.
3. Connect the other end to an Ethernet 10/100/1000 BaseT LAN.

The Brocade DCX 8510-8 can be accessed through a remote connection using the command line via Telnet or any of the management tools, such as Web Tools or Brocade Network Advisor.

4. To complete any additional Brocade DCX 8510-8 configuration procedures through a Telnet session, log in to the Brocade DCX 8510-8 by Telnet, using the **admin** login. The default password is *password*.

Customizing a switch name

The switch name of the Brocade DCX 8510-8 can be up to 30 characters long using Fabric OS release 7.0.0 or later; can include letters, numbers, hyphens, and underscore characters; and must begin with a letter.

NOTE

Changing the name causes a domain address format RSCN to be issued.

1. Enter **switchName** followed by the new name in double quotes.

```
swDir:admin> switchName "swModularSwitch5"  
Committing configuration...  
Done.  
swModularSwitch5:admin>
```

2. Record the new name for reference.

Customizing a chassis name

The chassis name of the Brocade DCX 8510-8 can be up to 15 characters long; can include letters, numbers, hyphens, and underscore characters; and must begin with a letter.

1. Enter **chassisName** followed by the new name in double quotes.

```
switch:admin> chassisname  
"DCX8510_chassis"  
Committing configuration...  
Done.
```

2. Enter **chassisName** by itself to show the name.

```
switch:admin> chassisname  
DCX8510_chassis
```

3. Record the new name for reference.

Setting the domain ID

Each switch in the fabric must have a unique domain ID. The domain ID can be manually set through the **configure** command or can be automatically set. The default domain ID for the Brocade DCX 8510-8 is 1. Use the **fabricShow** command to view the already assigned domain IDs.

1. Enter **switchDisable** to disable the Brocade DCX 8510-8.
2. Enter **configure**.

3. Enter **y** at the *Fabric parameters* prompt:

```
Fabric parameters (yes, y, no, n): [no] y
```

4. Enter a unique domain ID:

```
Domain: (1.239) [1] 3
```

5. Complete the remaining prompts or press **Ctrl+D** to accept the settings and exit.
6. Enter **switchEnable** to re-enable the Brocade DCX 8510-8.

Setting the date and time

The date and time settings are used for logging events. Switch operation does not depend on the date and time; a switch with an incorrect date and time value still functions properly. However, because the date and time are used for logging, error detection, and troubleshooting, they should be set correctly.

Setting the date

To set the date, follow these steps.

1. If necessary, log on to the Brocade DCX 8510-8 by Telnet, using the **admin** account.

The default password is password.

2. Enter the **date** command, using the following syntax:

```
date "mmdhHMMyy"
```

The values are:

- mm is the month; valid values are 01 through 12.
- dd is the date; valid values are 01 through 31.
- HH is the hour; valid values are 00 through 23.
- MM is minutes; valid values are 00 through 59.
- yy is the year; valid values are 00 through 99 (values greater than 69 are interpreted as 1970 through 1999, and values less than 70 are interpreted as 2000 through 2069).

```
switch:admin> date
Fri Sep 28 17:01:48 UTC 2010
switch:admin> date "0927123010"
Thu Sep 27 12:30:00 UTC 2010
switch:admin>
```

Setting the time zone

You must perform the procedure on *all* chassis for which the time zone must be set. However, you only need to set the time zone once on each switch, because the value is written to nonvolatile memory.

Use one of the two following procedures to set the time zone.

The following procedure describes how to set the current time zone using `timezone_fmt` mode to Central Standard time.

1. Log in to the switch using the default password, which is password.
2. Enter the **tsTimeZone** command as follows:

```
switch:admin> tstimezone [--interactive]/ [, timezone_fmt]
```

Use **timezone_fmt** to set the time zone by Country/City or by time zone ID, such as PST.

The following example shows how to change the time zone to US/Central.

```
switch:admin> tstimezone
Time Zone : US/Pacific
switch:admin> tstimezone US/Central
switch:admin> tstimezone
Time Zone : US/Central
```

The following procedure describes how to set the current time zone using interactive mode to Pacific Standard Time.

1. Enter the **tsTimeZone** command as follows:
switch:admin> tstimezone --interactive

You are prompted to select a general location.

Please identify a location so that time zone rules can be set correctly.

2. Enter the appropriate number or **Ctrl+D** to quit.
3. At the prompt, select a country location.
4. At the prompt, enter the appropriate number to specify the time zone region or **Ctrl+D** to quit.

Synchronizing local time

To synchronize the local time of the principal or primary switch with that of an external NTP server, follow these steps.

1. If necessary, log on to the switch by Telnet, using the **admin** account.
2. Enter the **tsClockServer** command:

```
switch:admin> tsclockserver
"<ntp1;ntp2>"
```

In this syntax, *ntp1* is the IP address or DNS name of the first NTP server, which the switch must be able to access. The variable *ntp2* is the second NTP server and is optional. The operand "<ntp1;ntp2>" is optional; by default, this value is LOCL, which uses the local clock of the principal or primary switch as the clock server.

The **tsClockServer** command accepts multiple server addresses in IPv4, IPv6, or DNS name formats. When multiple NTP server addresses are passed, **tsClockServer** sets the first obtainable address as the active NTP server. The rest will be stored as backup servers that can take over if the active NTP server fails. The principal or primary FCS switch synchronizes its time with the NTP server every 64 seconds.

```
switch:admin> tsclockserver
LOCL
switch:admin> tsclockserver "132.163.135.131"

switch:admin> tsclockserver
132.163.135.131
switch:admin>
```

The following example shows how to set up more than one NTP server using a DNS name:

```
switch:admin> tsclockserver "10.32.170.1;10.32.170.2;ntp.localdomain.net"
Updating Clock Server configuration...done.
Updated with the NTP servers
Changes to the clock server value on the principal or primary FCS switch are
propagated to all switches in the fabric
```

Verifying the PID mode

Before connecting the Brocade DCX 8510-8 to the fabric, verify that the WWN-based persistent port identifier (PID) feature on the Brocade DCX 8510-8 matches the other switches in the fabric. This parameter must be identical for all switches in the fabric and is set using the **configure** command as shown in the following example:

```
switch:admin>configure
Configure...
Fabric parameters (yes, y, no, n): [no] y
Domain: (1..239) [1]
Enable a 256 Area Limit
  (0 = No,
   1 = Zero Based Area Assignment,
   2 = Port Based Area Assignment): (0..2) [0] 1
WWN Based persistent PID (yes, y, no, n): [no] yes
<command output truncated>
```

You can check the PID setting using the **configshow** command as in the following example. You can use the `| grep -i pid` qualifier to pinpoint the PID information.

```
switch:admin> configshow | grep -i pid
fabric.ops.mode.pidFormat:1
fabric.wwnPidMode:1
```

The 1 indicates that the WWN-based persistent PID feature is enabled. The default value is 0 for disabled.

Determining installed software licenses

Depending on the vendor agreement, certain licenses are factory installed on the Brocade DCX 8510-8. To determine which licenses are enabled, use the **licenseShow** command.

```
swDir:admin> licenseshow
AAbbccDDeeFFeeGG:
  Web license
  Zoning license
  Extended Fabric license
  Fabric Watch license
  Performance Monitor license
  Trunking license
  Security license
```

In this example, the license key is AAbbccDDeeFFeeGG. Keep a copy of the license key for reference.

The 64-bit chassis ID is required to obtain and activate licenses for the Brocade DCX 8510-8. The chassis ID is available through the **licenseIdShow** command. The **licenseShow** and **licenseIdShow** commands must be entered on the active CP blade. Refer to the *Fabric OS Administrator's Guide* for more information.

Installing transceivers and attaching cables

The following two sets of steps cover the installation of transceivers and cables for most SFPs and for QSFPs.

Installing SFP+ and mSFP transceivers and cables

Complete the following steps to install SFP-type optical transceivers.

NOTE

mSFP transceivers are compatible only with the FC8-64 port blade. While they will fit in other blades, this configuration is unsupported and will generate an error.

1. Add the optical transceivers and cables to the Fibre Channel ports.

The ports are color-coded to indicate which can be used in the same port group for trunking (trunking port groups can be up to 8 ports). The ports and cables used in trunking groups must meet specific requirements. Refer to the *Fabric OS Administrator's Guide*.
2. Position one of the optical transceivers so that the key is oriented correctly to the port. Insert the transceiver into the port until it is firmly seated and the latching mechanism clicks.

Transceivers are keyed so that they can only be inserted with the correct orientation. If a transceiver does not slide in easily, ensure that it is correctly oriented.
3. Position a cable so that the key (the ridge on one side of the cable connector) is aligned with the slot in the transceiver. Insert the cable into the transceiver until the latching mechanism clicks.

Cables are keyed so that they can be inserted in only one way. If a cable does not slide in easily, ensure that it is correctly oriented.
4. Repeat steps 1 through 3 for the remaining ports.
5. Organize the cables. Refer to [Managing cables](#) on page 46.
6. Verify the Brocade DCX 8510-8 and port status using the **switchShow** command.
7. Verify fabric connectivity using the **fabricShow** command.

Qualified transceivers for the FC16-64 port blade and the core blades

The following table shows the qualified transceivers for the FC16-64 port blade and the core blades.

TABLE 4 Qualified transceivers for FC16-64 port blade and the core blades

| Brocade part number | Part type | Cable length | Port speeds | Supported blades |
|---------------------|------------------|--------------|-------------------------------------|------------------|
| 57-1000294-01 | QSFP transceiver | 100 m OM4 | Auto-negotiable 4-, 8-, and 16-Gbps | FC16-64 |
| 57-1000267-01 | QSFP transceiver | 100 m OM4 | Only fixed 16-Gbps | CR16-4/8 |
| 57-0000090-01 | QSFP transceiver | 50 m OM3 | | |

NOTE

The QSFP transceivers supported on FC16-64 port blade are not interchangeable with QSFP transceivers supported on the core blades.

Installing QSFP transceivers and cables

Follow these steps to install the QSFPs and cables in the FC16-64 port blades and the 16-Gbps core blades. In the core blades, these transceivers and cables are used to form the inter-chassis links (ICLs) with neighboring DCX 8510 Backbones. The transceivers should be installed in the blades before connecting the cables. Because each QSFP contains four 16-Gbps ports, be aware that any problems with one port could affect all four ports in the quad if the QSFP must be replaced.

NOTE

Even though the installation and removal procedures are the same for QSFP ports in FC16-64 port blades and the core blades, the physical QSFP transceivers designed for FC16-64 are not compatible with the QSFP transceivers designed for the core blades. They are not interchangeable.

1. Position one of the QSFP transceivers so that the key is oriented correctly to the port. Insert the transceiver into the port until it is firmly seated.

Transceivers are keyed so that they can only be inserted with the correct orientation. If a transceiver does not slide in easily, ensure that it is correctly oriented.

When the transceiver is correctly seated, the status LED will flash amber several times and then turn solid amber.

2. Remove the protective cap from the special QSFP cable and insert it into the transceiver until it is firmly seated.

The cables are also keyed to fit into the transceivers correctly.

When the cable is correctly seated, the status LED will change from amber to green.

Repeat steps 1 and 2 for the remaining QSFP ports.

3. Organize the cables. Refer to [Cable management](#) on page 29
4. Verify the Brocade DCX 8510-8 and connector and port status using the **switchShow -qsfp** command.

The following example is from a DCX 8510-4 with a core blade installed in slot 3. Some details for the DCX 8510-8 will be different, but the reported information for the QSFPs will be similar.

Note that the State reported for an unconnected QSFP (shown QSFP 0 and Ports 0-3 in the example) is No_SigDet. This is different from the State of No_Synch that is reported for regular SFPs that are unconnected.

QSFP 7 (ports 3/28-3/31, Index 748-751) in the following example shows the results for a connected QSFP.

```
switch:FID128:admin> switchshow -qsfp
switchName:      switch name
switchType:      121.3
switchState:     Online
switchMode:      Native
switchRole:      Subordinate
switchDomain:    75
switchId:        fffc4b
switchWwn:       10:00:00:05:1e:4f:eb:00
zoning:          ON (zoning name)
)
switchBeacon:    OFF
FC Router:       OFF
Allow XISL Use:  OFF
LS Attributes:   [FID: 128, Base Switch: No, Default Switch: Yes, Address Mode 0]
Index Slot Port QSFP Address Media Speed State Proto
=====
256  3  0  0  ----- id  16G  No_SigDet  FC
257  3  1  0  ----- id  16G  No_SigDet  FC
258  3  2  0  ----- id  16G  No_SigDet  FC
259  3  3  0  ----- id  16G  No_SigDet  FC
```

| | | | | | | | | | | | | | | | | | | | |
|---------------------------|---|----|---|-------|----|-----|-----------|----|--------|-----------------|--|--|--|--|--|--|--|--|--|
| 260 | 3 | 4 | 1 | ----- | -- | 16G | No_Module | FC | | | | | | | | | | | |
| 261 | 3 | 5 | 1 | ----- | -- | 16G | No_Module | FC | | | | | | | | | | | |
| 262 | 3 | 6 | 1 | ----- | -- | 16G | No_Module | FC | | | | | | | | | | | |
| 263 | 3 | 7 | 1 | ----- | -- | 16G | No_Module | FC | | | | | | | | | | | |
| 264 | 3 | 8 | 2 | ----- | -- | 16G | No_Module | FC | | | | | | | | | | | |
| 265 | 3 | 9 | 2 | ----- | -- | 16G | No_Module | FC | | | | | | | | | | | |
| 266 | 3 | 10 | 2 | ----- | -- | 16G | No_Module | FC | | | | | | | | | | | |
| 267 | 3 | 11 | 2 | ----- | -- | 16G | No_Module | FC | | | | | | | | | | | |
| 268 | 3 | 12 | 3 | ----- | -- | 16G | No_Module | FC | | | | | | | | | | | |
| 269 | 3 | 13 | 3 | ----- | -- | 16G | No_Module | FC | | | | | | | | | | | |
| 270 | 3 | 14 | 3 | ----- | -- | 16G | No_Module | FC | | | | | | | | | | | |
| 271 | 3 | 15 | 3 | ----- | -- | 16G | No_Module | FC | | | | | | | | | | | |
| 736 | 3 | 16 | 4 | ----- | -- | 16G | No_Module | FC | | | | | | | | | | | |
| 737 | 3 | 17 | 4 | ----- | -- | 16G | No_Module | FC | | | | | | | | | | | |
| 738 | 3 | 18 | 4 | ----- | -- | 16G | No_Module | FC | | | | | | | | | | | |
| 739 | 3 | 19 | 4 | ----- | -- | 16G | No_Module | FC | | | | | | | | | | | |
| 740 | 3 | 20 | 5 | ----- | -- | 16G | No_Module | FC | | | | | | | | | | | |
| 741 | 3 | 21 | 5 | ----- | -- | 16G | No_Module | FC | | | | | | | | | | | |
| 742 | 3 | 22 | 5 | ----- | -- | 16G | No_Module | FC | | | | | | | | | | | |
| 743 | 3 | 23 | 5 | ----- | -- | 16G | No_Module | FC | | | | | | | | | | | |
| 744 | 3 | 24 | 6 | ----- | -- | 16G | No_Module | FC | | | | | | | | | | | |
| 745 | 3 | 25 | 6 | ----- | -- | 16G | No_Module | FC | | | | | | | | | | | |
| 746 | 3 | 26 | 6 | ----- | -- | 16G | No_Module | FC | | | | | | | | | | | |
| 747 | 3 | 27 | 6 | ----- | -- | 16G | No_Module | FC | | | | | | | | | | | |
| 748 | 3 | 28 | 7 | ----- | id | 16G | Online | FC | E-Port | 10:00:00:05:1e: | | | | | | | | | |
| 39:e4:5a trunkmaster name | | | | | | | | | | | | | | | | | | | |
| (Trunk master) | | | | | | | | | | | | | | | | | | | |
| 749 | 3 | 29 | 7 | ----- | id | 16G | Online | FC | E-Port | 10:00:00:05:1e: | | | | | | | | | |
| 39:e4:5a trunkmaster name | | | | | | | | | | | | | | | | | | | |
| (Trunk master) | | | | | | | | | | | | | | | | | | | |
| 750 | 3 | 30 | 7 | ----- | id | 16G | Online | FC | E-Port | 10:00:00:05:1e: | | | | | | | | | |
| 39:e4:5a trunkmaster name | | | | | | | | | | | | | | | | | | | |
| (Trunk master) | | | | | | | | | | | | | | | | | | | |
| 751 | 3 | 31 | 7 | ----- | id | 16G | Online | FC | E-Port | 10:00:00:05:1e: | | | | | | | | | |
| 39:e4:5a trunkmaster name | | | | | | | | | | | | | | | | | | | |
| (Trunk master) | | | | | | | | | | | | | | | | | | | |

Managing cables

Cables can be organized and managed in a variety of ways, for example, using cable channels on the port sides of the cabinet or patch panels to minimize cable management. On the Brocade DCX 8510-8 the cable management comb is located below the blades on the port side.

Following is a list of recommendations:

- Leave at least 1 m (3.28 ft) of slack for each port cable. This provides room to remove and replace the Brocade DCX 8510-8, allows for inadvertent movement of the rack, and helps prevent the cables from being bent to less than the minimum bend radius.
- The minimum bend radius should be no smaller than ten times the cable radius. The minimum radius to which a 50 micron cable can be bent under full tensile load is 5.1 cm (2 in.). For a cable under no tensile load, that minimum is 3.0 cm (1.2 in.).
- If ISL Trunking is in use, group the cables by trunking group. The ports are color-coded to indicate which ports can be used in the same ISL Trunking group: eight ports marked with solid black ovals alternate with eight ports marked with oval outlines.
- Generally, Velcro® type cable restraints are recommended to avoid creating sharp bends in the cables. Do not use tie wraps with optical cables because they are easily overtightened and can damage the optic fibers.
- For easier maintenance, label the fiber optic cables and record the devices to which they are connected.
- Do not route cables in front of the air exhaust vents.
- Route the cables to the bottom of the Brocade DCX 8510-8 through the cable management comb.
- Keep LEDs visible by routing port cables and other cables away from the LEDs.

NOTE

Refer to "Cabling Best Practices" (available at <http://www.brocade.com>) for cable management guidelines.

For the procedure to install the ICL cables, refer to [Inter-chassis link \(ICL\) cable removal and replacement](#) on page 108

Verifying correct operation and backing up the configuration

To verify correct operation and back up the Brocade DCX 8510-8 configuration, follow these steps. For information about LED patterns, refer to [Determining the status of a port or application blade](#) on page 54.

Complete the following steps to back up the configuration for the Brocade DCX 8510-8.

1. Check the LEDs to verify that all components are functional.
2. If necessary, log in to the switch by Telnet, using the **admin** account.
3. Verify the correct operation of the Brocade DCX 8510-8 by entering the **switchShow** command from the workstation. This command provides information about switch and port status.
4. Verify the correct operation of the Brocade DCX 8510-8 in the fabric by entering the **fabricShow** command from the workstation. This command provides general information about the fabric.
5. To back up the configuration, run the following two steps:
 - a) Enter the **configupload -vf** command. This command uploads the Brocade DCX 8510-8 virtual fabric data.
 - b) Enter the **configupload** command. This command uploads the Brocade DCX 8510-8 configuration.
6. You can run the following commands to see additional configuration information that you can copy to a file to save:
 - **configShow**
 - **ipaddrShow**
 - **licenseShow**
 - **switchShow**

Alternatively, you can save the configuration file to a Brocade USB device by using the **usbstorage** command.

NOTE

Passwords are not saved in the configuration file, and are not uploaded during a configuration upload.

NOTE

It is recommended that the configuration be backed up on a regular basis to ensure that a complete configuration is available for downloading to a replacement Brocade DCX 8510-8.

Powering off the Brocade DCX 8510-8

Perform the following steps to power off the Brocade DCX 8510-8.

1. Shut down the Brocade DCX 8510-8 using the **sysShutdown** command.

```
switch::admin> sysshutdown
This command will shutdown the operating systems on your switch.
You are required to power-cycle the switch in order to restore operation.
Are you sure you want to shutdown the switch [y/n]?y
HA is disabled
Stopping blade 1
Shutting down the blade....
Stopping blade 2
Shutting down the blade....
Stopping blade 8
Shutting down the blade....
Broadcast message from root (pts/1) Tue Aug 23 14:23:06 2010...
The system is going down for system halt NOW !!
```

2. Power off the chassis by flipping the AC power switches on the power supplies to O (LEDs inside AC power switches should turn off). To maintain the ground connections, leave power cords connected to the power supplies and to the electrical outlets.

Monitoring System Components

- [Monitoring overview.....](#) 49
- [Determining the status of a port or application blade.....](#) 54
- [Determining the status of a control processor blade \(CP8\).....](#) 65
- [Determining the status of a core switch blade \(CR16-8\).....](#) 67
- [Determining the status of a power supply.....](#) 69
- [Determining the status of a blower assembly.....](#) 70
- [Determining the status of a WWN card.....](#) 72

Monitoring overview

The Brocade DCX 8510-8 is engineered for reliability and requires no routine operational steps or maintenance. This chapter provides information about determining the status of each component using LEDs and CLI commands. Refer to the *Web Tools Administrator's Guide* and the *Fabric OS Administrator's Guide* for additional information.

There are two commands that can be especially helpful in monitoring the health of the Brocade DCX 8510-8. These commands are **switchShow** and **chassisShow**.

Note in the **switchShow** command the new switchType for the Brocade DCX 8510-8 as well as the 16-Gbps speed identification for capable ports. The output has been truncated to reduce information duplication.

```
DCX_8510_8:admin> switchshow
switchName:      DCX_8510_8
switchType:      120_3
switchState:     Online
switchMode:      Native
switchRole:      Subordinate
switchDomain:    120
switchId:        fffc78
switchWwn:       10:00:00:05:1e:d2:64:00
zoning:          ON (BB)
switchBeacon:    OFF
FC Router:       ON
FC Router BB Fabric ID: 10
Address Mode:    0
Index Slot Port Address Media  Speed  State      Proto
=====
EX_Ports) 0 1 0 780000 id N8 No_Light FC Disabled (Switch not ready for
EX_Ports) 1 1 1 780100 id N8 No_Light FC Disabled (Switch not ready for
EX_Ports) 2 1 2 780200 -- N8 No_Module FC Disabled (Switch not ready for
EX_Ports) 3 1 3 780300 -- N8 No_Module FC Disabled (Switch not ready for
EX_Ports) 4 1 4 780400 id N8 No_Light FC Disabled (Switch not ready for
EX_Ports) 5 1 5 780500 id N8 No_Light FC Disabled (Switch not ready for
EX_Ports) 6 1 6 780600 id N8 No_Light FC
7 1 7 780700 id 4G No_Light FC
8 1 8 780800 -- N8 No_Module FC
9 1 9 780900 -- N8 No_Module FC
10 1 10 780a00 -- N8 No_Module FC
11 1 11 780b00 -- N8 No_Module FC
```

Monitoring System Components

| | | | | | | | | | | |
|-----|------|----|--------|----|-----|-----------|-------------|-----------------------|------------|----------|
| 12 | 1 | 12 | 780c00 | -- | -- | Offline | VE | Disabled (Persistent) | | |
| 13 | 1 | 13 | 780d00 | -- | -- | Offline | VE | | | |
| 14 | 1 | 14 | 780e00 | -- | -- | Offline | VE | | | |
| 15 | 1 | 15 | 780f00 | -- | -- | Offline | VE | | | |
| 128 | 1 | 16 | 788000 | -- | -- | Offline | VE | | | |
| 129 | 1 | 17 | 788100 | -- | -- | Offline | VE | | | |
| 130 | 1 | 18 | 788200 | -- | -- | Offline | VE | | | |
| 131 | 1 | 19 | 788300 | -- | -- | Offline | VE | | | |
| 132 | 1 | 20 | 788400 | -- | -- | Offline | VE | | | |
| 133 | 1 | 21 | 788500 | -- | -- | Offline | VE | | | |
| 134 | 1 | 22 | 788600 | -- | -- | Offline | VE | Disabled (Persistent) | | |
| 135 | 1 | 23 | 788700 | -- | -- | Offline | VE | | | |
| 136 | 1 | 24 | 788800 | -- | -- | Offline | VE | | | |
| 137 | 1 | 25 | 788900 | -- | -- | Offline | VE | | | |
| 138 | 1 | 26 | 788a00 | -- | -- | Offline | VE | | | |
| 139 | 1 | 27 | 788b00 | -- | -- | Offline | VE | | | |
| 140 | 1 | 28 | 788c00 | -- | -- | Offline | VE | | | |
| 141 | 1 | 29 | 788d00 | -- | -- | Offline | VE | | | |
| 142 | 1 | 30 | 788e00 | -- | -- | Offline | VE | | | |
| 143 | 1 | 31 | 788f00 | -- | -- | Offline | VE | | | |
| 1 | ge0 | | | -- | 1G | No_Module | FCIP | Disabled | (10G Mode) | |
| 1 | ge1 | | | -- | 1G | No_Module | FCIP | Disabled | (10G Mode) | |
| 1 | ge2 | | | -- | 1G | No_Module | FCIP | Disabled | (10G Mode) | |
| 1 | ge3 | | | -- | 1G | No_Module | FCIP | Disabled | (10G Mode) | |
| 1 | ge4 | | | -- | 1G | No_Module | FCIP | Disabled | (10G Mode) | |
| 1 | ge5 | | | -- | 1G | No_Module | FCIP | Disabled | (10G Mode) | |
| 1 | ge6 | | | -- | 1G | No_Module | FCIP | Disabled | (10G Mode) | |
| 1 | ge7 | | | -- | 1G | No_Module | FCIP | Disabled | (10G Mode) | |
| 1 | ge8 | | | -- | 1G | No_Module | FCIP | Disabled | (10G Mode) | |
| 1 | ge9 | | | -- | 1G | No_Module | FCIP | Disabled | (10G Mode) | |
| 1 | xge0 | | | id | 10G | No_Light | FCIP | | | |
| 1 | xge1 | | | id | 10G | No_Light | FCIP | | | |
| 32 | 3 | 0 | 782000 | id | N8 | No_Light | FC | | | |
| 33 | 3 | 1 | 782100 | id | N8 | No_Light | FC | | | |
| 34 | 3 | 2 | 782200 | -- | N8 | No_Module | FC | | | |
| 35 | 3 | 3 | 782300 | id | N8 | No_Light | FC | | | |
| 36 | 3 | 4 | 782400 | -- | N8 | No_Module | FC | | | |
| 37 | 3 | 5 | 782500 | -- | N8 | No_Module | FC | | | |
| 38 | 3 | 6 | 782600 | -- | N8 | No_Module | FC | | | |
| 39 | 3 | 7 | 782700 | -- | N8 | No_Module | FC | | | |
| 40 | 3 | 8 | 782800 | id | N8 | No_Light | FC | | | |
| 41 | 3 | 9 | 782900 | id | N8 | No_Light | FC | | | |
| 42 | 3 | 10 | 782a00 | -- | N8 | No_Module | FC | | | |
| 43 | 3 | 11 | 782b00 | -- | N8 | No_Module | FC | | | |
| 44 | 3 | 12 | 782c00 | id | N8 | No_Light | FC | | | |
| 45 | 3 | 13 | 782d00 | id | N8 | No_Light | FC | | | |
| 46 | 3 | 14 | 782e00 | -- | N8 | No_Module | FC | | | |
| 47 | 3 | 15 | 782f00 | -- | N8 | No_ | 3 20 78a400 | id | N8 | No_Light |
| FC | | | | | | | | | | |
| 165 | 3 | 21 | 78a500 | -- | N8 | No_Module | FC | | | |
| 166 | 3 | 22 | 78a600 | id | N8 | No_Light | FC | | | |
| 167 | 3 | 23 | 78a700 | -- | N8 | No_Module | FC | | | |
| 168 | 3 | 24 | 78a800 | -- | N8 | No_Module | FC | | | |
| 169 | 3 | 25 | 78a900 | id | N8 | No_Light | FC | | | |
| 170 | 3 | 26 | 78aa00 | -- | N8 | No_Module | FC | | | |
| 171 | 3 | 27 | 78ab00 | -- | N8 | No_Module | FC | | | |
| 172 | 3 | 28 | 78ac00 | -- | N8 | No_Module | FC | | | |
| 173 | 3 | 29 | 78ad00 | -- | N8 | No_Module | FC | | | |
| 174 | 3 | 30 | 78ae00 | -- | N8 | No_Module | FC | | | |
| 175 | 3 | 31 | 78af00 | -- | N8 | No_Module | FC | | | |
| 288 | 3 | 32 | 78a880 | id | N8 | No_Light | FC | | | |
| 289 | 3 | 33 | 78a980 | id | N8 | No_Light | FC | | | |
| 290 | 3 | 34 | 78aa80 | id | N8 | No_Light | FC | | | |
| 291 | 3 | 35 | 78ab80 | id | N8 | No_Light | FC | | | |
| 292 | 3 | 36 | 78ac80 | id | N8 | No_Light | FC | | | |
| 293 | 3 | 37 | 78ad80 | id | N8 | No_Light | FC | | | |
| 294 | 3 | 38 | 78ae80 | id | N8 | No_Light | FC | | | |
| 295 | 3 | 39 | 78af80 | id | N8 | No_Light | FC | | | |
| 296 | 3 | 40 | 78a080 | id | N8 | No_Light | FC | | | |
| 297 | 3 | 41 | 78a180 | -- | N8 | No_Module | FC | | | |
| 298 | 3 | 42 | 78a280 | -- | N8 | No_Module | FC | | | |
| 299 | 3 | 43 | 78a380 | -- | N8 | No_Module | FC | | | |
| 300 | 3 | 44 | 78a480 | -- | N8 | No_Module | FC | | | |
| 301 | 3 | 45 | 78a580 | -- | N8 | No_Module | FC | | | |
| 302 | 3 | 46 | 78a680 | -- | N8 | No_Module | FC | | | |
| 303 | 3 | 47 | 78a780 | -- | N8 | No_Module | FC | | | |
| 800 | 3 | 48 | 782080 | id | N8 | No_Light | FC | | | |
| 801 | 3 | 49 | 782180 | -- | N8 | No_Module | FC | | | |

| | | | | | | | | |
|------------------------|---|----|--------|----|-----|-----------|----|--------------------------------|
| 802 | 3 | 50 | 782280 | -- | N8 | No_Module | FC | |
| 803 | 3 | 51 | 782380 | id | N8 | No_Light | FC | |
| 804 | 3 | 52 | 782480 | -- | N8 | No_Module | FC | |
| 805 | 3 | 53 | 782580 | -- | N8 | No_Module | FC | |
| 806 | 3 | 54 | 782680 | -- | N8 | No_Module | FC | |
| 807 | 3 | 55 | 782780 | id | N8 | No_Light | FC | |
| 808 | 3 | 56 | 782880 | -- | N8 | No_Module | FC | |
| 809 | 3 | 57 | 782980 | -- | N8 | No_Module | FC | |
| 810 | 3 | 58 | 782a80 | -- | N8 | No_Module | FC | |
| 811 | 3 | 59 | 782b80 | -- | N8 | No_Module | FC | |
| 812 | 3 | 60 | 782c80 | -- | N8 | No_Module | FC | |
| 813 | 3 | 61 | 782d80 | -- | N8 | No_Module | FC | |
| 814 | 3 | 62 | 782e80 | -- | N8 | No_Module | FC | |
| 815 | 3 | 63 | 782f80 | -- | N8 | No_Module | FC | |
| 48 | 4 | 0 | 783000 | id | N8 | No_Light | FC | |
| 49 | 4 | 1 | 783100 | id | N8 | No_Light | FC | |
| 50 | 4 | 2 | 783200 | id | N8 | No_Light | FC | |
| 51 | 4 | 3 | 783300 | id | N8 | No_Light | FC | |
| 52 | 4 | 4 | 783400 | id | N8 | No_Light | FC | |
| 53 | 4 | 5 | 783500 | id | N8 | No_Light | FC | |
| 54 | 4 | 6 | 783600 | id | N8 | No_Light | FC | |
| 55 | 4 | 7 | 783700 | id | N8 | No_Light | FC | |
| 56 | 4 | 8 | 783800 | id | N8 | No_Light | FC | |
| 57 | 4 | 9 | 783900 | id | N8 | No_Light | FC | |
| 58 | 4 | 10 | 783a00 | id | N8 | No_Light | FC | |
| 59 | 4 | 11 | 783b00 | id | N8 | No_Light | FC | |
| 60 | 4 | 12 | 783c00 | id | N8 | No_Light | FC | |
| 61 | 4 | 13 | 783d00 | id | N8 | No_Light | FC | |
| 62 | 4 | 14 | 783e00 | id | N8 | No_Light | FC | |
| 63 | 4 | 15 | 783f00 | id | N8 | No_Light | FC | |
| 176 | 4 | 16 | 78b000 | id | N8 | No_Light | FC | |
| 177 | 4 | 17 | 78b100 | id | N8 | No_Light | FC | |
| 178 | 4 | 18 | 78b200 | id | N8 | No_Light | FC | |
| 179 | 4 | 19 | 78b300 | id | N8 | No_Light | FC | |
| 180 | 4 | 20 | 78b400 | id | N8 | No_Light | FC | |
| 181 | 4 | 21 | 78b500 | id | N8 | No_Light | FC | |
| 182 | 4 | 22 | 78b600 | id | N8 | No_Light | FC | |
| 183 | 4 | 23 | 78b700 | id | AN | No_Sync | FC | |
| 184 | 4 | 24 | 78b800 | -- | N16 | No_Module | FC | |
| 185 | 4 | 25 | 78b900 | -- | N16 | No_Module | FC | |
| 186 | 4 | 26 | 78ba00 | -- | N16 | No_Module | FC | |
| 187 | 4 | 27 | 78bb00 | -- | N16 | No_Module | FC | |
| 188 | 4 | 28 | 78bc00 | id | N8 | No_Light | FC | |
| 189 | 4 | 29 | 78bd00 | id | N8 | No_Light | FC | |
| 190 | 4 | 30 | 78be00 | id | 8 | No_Light | FC | |
| 190 | 4 | 30 | 78be00 | id | N8 | No_Light | FC | |
| 191 | 4 | 31 | 78bf00 | id | N8 | No_Light | FC | |
| 304 | 4 | 32 | 78b880 | -- | N16 | No_Module | FC | |
| 305 | 4 | 33 | 78b980 | -- | N16 | No_Module | FC | |
| 306 | 4 | 34 | 78ba80 | -- | N16 | No_Module | FC | |
| 307 | 4 | 35 | 78bb80 | -- | N16 | No_Module | FC | |
| 308 | 4 | 36 | 78bc80 | -- | N16 | No_Module | FC | |
| 309 | 4 | 37 | 78bd80 | -- | N16 | No_Module | FC | |
| 310 | 4 | 38 | 78be80 | id | N8 | No_Light | FC | |
| 311 | 4 | 39 | 78bf80 | id | N8 | No_Light | FC | |
| 312 | 4 | 40 | 78b080 | -- | N16 | No_Module | FC | |
| 313 | 4 | 41 | 78b180 | -- | N16 | No_Module | FC | |
| 314 | 4 | 42 | 78b280 | -- | N16 | No_Module | FC | |
| 315 | 4 | 43 | 78b380 | -- | N16 | No_Module | FC | |
| 316 | 4 | 44 | 78b480 | -- | N16 | No_Module | FC | |
| 317 | 4 | 45 | 78b580 | id | N16 | No_Light | FC | |
| 318 | 4 | 46 | 78b680 | id | N16 | No_Light | FC | |
| 319 | 4 | 47 | 78b780 | id | N16 | Online | FC | |
| "DCX4S_130" (upstream) | | | | | | | | |
| 384 | 5 | 0 | ----- | -- | 16G | No_Module | FC | |
| 385 | 5 | 1 | ----- | -- | 16G | No_Module | FC | |
| 386 | 5 | 2 | ----- | -- | 16G | No_Module | FC | |
| 387 | 5 | 3 | ----- | -- | 16G | No_Module | FC | |
| 388 | 5 | 4 | ----- | -- | 16G | No_Module | FC | |
| 389 | 5 | 5 | ----- | -- | 16G | No_Module | FC | |
| 390 | 5 | 6 | ----- | -- | 16G | No_Module | FC | |
| 391 | 5 | 7 | ----- | -- | 16G | No_Module | FC | |
| 392 | 5 | 8 | ----- | -- | 16G | No_Module | FC | |
| 393 | 5 | 9 | ----- | -- | 16G | No_Module | FC | |
| 394 | 5 | 10 | ----- | -- | 16G | No_Module | FC | |
| 395 | 5 | 11 | ----- | -- | 16G | No_Module | FC | |
| 396 | 5 | 12 | ----- | id | 16G | No_SigDet | FC | |
| 397 | 5 | 13 | ----- | id | 16G | No_SigDet | FC | |
| | | | | | | | | E-Port 10:00:00:05:33:03:2c:00 |

```

398 5 14 ----- id 16G No_SigDet FC
399 5 15 ----- id 16G No_SigDet FC
400 5 16 ----- id 16G No_SigDet FC
401 5 17 ----- id 16G No_SigDet FC
402 5 18 ----- id 16G No_SigDet FC
403 5 19 ----- id 16G No_SigDet FC
404 5 20 ----- id 16G No_SigDet FC
405 5 21 ----- id 16G No_SigDet FC
406 5 22 ----- id 16G No_SigDet FC
407 5 23 ----- id 16G No_SigDet FC
408 5 24 ----- id 16G No_SigDet FC
409 5 25 ----- id 16G No_SigDet FC
410 5 26 ----- id 16G No_SigDet FC
411 5 27 ----- id 16G No_SigDet FC
412 5 28 ----- id 16G No_SigDet FC
413 5 29 ----- id 16G No_SigDet FC
414 5 30 ----- id 16G No_SigDet FC
415 5 31 ----- id 16G No_SigDet FC
1152 5 32 ----- -- 16G No_Module FC
1153 5 33 ----- -- 16G No_Module FC
1154 5 34 ----- -- 16G No_Module FC
1155 5 35 ----- -- 16G No_Module FC
1156 5 36 ----- -- 16G No_Module FC
1157 5 37 ----- -- 16G No_Module FC
1158 5 38 ----- -- 16G No_Module FC
1159 5 39 ----- -- 16G No_Module FC
1160 5 40 ----- -- 16G No_Module FC
1161 5 41 ----- -- 16G No_Module FC
1162 5 42 ----- -- 16G No_Module FC
1163 5 43 ----- -- 16G No_Module FC
1164 5 44 ----- -- 16G No_Module FC
1165 5 45 ----- -- 16G No_Module FC
1166 5 46 ----- -- 16G No_Module FC
1167 5 47 ----- -- 16G No_Module FC
1168 5 48 ----- -- 16G No_Module FC
1169 5 49 ----- -- 16G No_Module FC
1170 5 50 ----- -- 16G No_Module FC
1171 5 51 ----- -- 16G No_Module FC
1172 5 52 ----- -- 16G No_Module FC
1173 5 53 ----- -- 16G No_Module FC
1174 5 54 ----- -- 16G No_Module FC
<output truncated>
DCX_8510_8:admin>

```

Note in the **chassisShow** command the Chassis Family designation for the Brocade DCX 8510-8 along with specific information about every field-replaceable unit in the chassis.

```

DCX_8510_8:admin> chassisshow
Chassis Family: DCX8510-8
Chassis Backplane Revision: 0
AP BLADE Slot: 1
Header Version: 2
Power Consume Factor: -250
Factory Part Num: 60-1001157-21
Factory Serial Num: ATM0427F01F
Manufacture: Day: 12 Month: 7 Year: 2010
Update: Day: 27 Month: 3 Year: 2011
Time Alive: 45 days
Time Awake: 0 days
SW BLADE Slot: 3
Header Version: 2
Power Consume Factor: -130
Factory Part Num: 60-0000071-07
Factory Serial Num: BAH0344E01G
Manufacture: Day: 2 Month: 11 Year: 2009
Update: Day: 7 Month: 2 Year: 2011
Time Alive: 280 days
Time Awake: 0 days
SW BLADE Slot: 4
Header Version: 2
Power Consume Factor: -160
Power Usage (Watts): -100
Factory Part Num: 60-1002144-02
Factory Serial Num: BQB0349F00G
Manufacture: Day: 10 Month: 12 Year: 2010
Update: Day: 28 Month: 3 Year: 2011

```

```

Time Alive:          14 days
Time Awake:          0 days
CP BLADE Slot: 6
Header Version:      2
Power Consume Factor: -40
Factory Part Num:    60-1000376-08
Factory Serial Num:  AHJ0449E042
Manufacture:         Day: 14 Month: 12 Year: 2009
Update:              Day: 28 Month: 3 Year: 2011
Time Alive:          299 days
Time Awake:          0 days
CP BLADE Slot: 7
Header Version:      2
Power Consume Factor: -40
Factory Part Num:    60-1000376-08
Factory Serial Num:  AHJ0448E0AK
Manufacture:         Day: 15 Month: 12 Year: 2009
Update:              Day: 28 Month: 3 Year: 2011
Time Alive:          312 days
Time Awake:          0 days
CORE BLADE Slot: 5
Header Version:      2
Power Consume Factor: -240
Power Usage (Watts): -154
Factory Part Num:    60-1002140-02
Factory Serial Num:  BPZ0349F00G
Manufacture:         Day: 7 Month: 12 Year: 2010
Update:              Day: 28 Month: 3 Year: 2011
Time Alive:          49 days
Time Awake:          0 days
CORE BLADE Slot: 8
Header Version:      2
Power Consume Factor: -240
Power Usage (Watts): -148
Factory Part Num:    60-1002140-02
Factory Serial Num:  BPZ0349F006
Manufacture:         Day: 7 Month: 12 Year: 2010
Update:              Day: 28 Month: 3 Year: 2011
Time Alive:          46 days
Time Awake:          0 days
SW BLADE Slot: 11
Header Version:      2
Power Consume Factor: -160
Power Usage (Watts): -115
Factory Part Num:    60-1002144-02
Factory Serial Num:  BQB0345F00T
Manufacture:         Day: 11 Month: 11 Year: 2010
Update:              Day: 28 Month: 3 Year: 2011
Time Alive:          30 days
Time Awake:          0 days
SW BLADE Slot: 12
Header Version:      2
Power Consume Factor: -160
Power Usage (Watts): -79
Factory Part Num:    60-1002144-02
Factory Serial Num:  BQB0345F012
Manufacture:         Day: 20 Month: 11 Year: 2010
Update:              Day: 28 Month: 3 Year: 2011
Time Alive:          3 days
Time Awake:          0 days
POWER SUPPLY Unit: 1
Header Version:      2
Power Consume Factor: 2000
Factory Part Num:    23-0000067-01
Factory Serial Num:  AGC2M44EKPH
Manufacture:         Day: 29 Month: 12 Year: 2009
Update:              Day: 28 Month: 3 Year: 2011
Time Alive:          319 days
Time Awake:          0 days
POWER SUPPLY Unit: 3
Header Version:      2
Power Consume Factor: 2000
Factory Part Num:    23-0000067-01
Factory Serial Num:  AGC2M44EKPL
Manufacture:         Day: 29 Month: 12 Year: 2009
Update:              Day: 28 Month: 3 Year: 2011
Time Alive:          319 days
Time Awake:          0 days

```

```
FAN Unit: 1
Header Version: 2
Power Consume Factor: -126
Factory Part Num: 60-1000384-09
Factory Serial Num: AGB0652E0HA
Manufacture: Day: 29 Month: 12 Year: 2009
Update: Day: 28 Month: 3 Year: 2011
Time Alive: 319 days
Time Awake: 0 days
FAN Unit: 2
Header Version: 2
Power Consume Factor: -126
Factory Part Num: 60-1000384-09
Factory Serial Num: AGB0652E0H9
Manufacture: Day: 29 Month: 12 Year: 2009
Update: Day: 28 Month: 3 Year: 2011
Time Alive: 319 days
Time Awake: 0 days
FAN Unit: 3
Header Version: 2
Power Consume Factor: -126
Factory Part Num: 60-1000384-09
Factory Serial Num: AGB0652E0H8
Manufacture: Day: 29 Month: 12 Year: 2009
Update: Day: 28 Month: 3 Year: 2011
Time Alive: 319 days
Time Awake: 0 days
WWN Unit: 1
Header Version: 2
Power Consume Factor: -1
Factory Part Num: 60-1000491-05
Factory Serial Num: AFX0602F001
Manufacture: Day: 29 Month: 12 Year: 2009
Update: Day: 28 Month: 3 Year: 2011
Time Alive: 319 days
Time Awake: 0 days
ID: BRD0000CA
Part Num: SLKWRM0000DCX
WWN Unit: 2
Header Version: 2
Power Consume Factor: -1
Factory Part Num: 60-1000491-05
Factory Serial Num: AJX0446E009
Manufacture: Day: 29 Month: 12 Year: 2009
Update: Day: 28 Month: 3 Year: 2011
Time Alive: 319 days
Time Awake: 0 days
Chassis Factory Serial Num: AFY0601F007
DCX_8510_8:admin>
```

Determining the status of a port or application blade

Use the following procedure to determine the status of a port or application blade.

1. Check the LEDs on the blade. Refer to [Blade illustrations](#) on page 54.

The LED patterns may temporarily change during POST and other diagnostic tests. For information about how to interpret the LED patterns, refer to the table following the blade descriptions.

2. Check the blade status by entering **slotShow**.

Blade illustrations

NOTE

The FC8-64 port blade requires narrower OM-3 LC cables offered by major manufacturers like Corning, Molex, and Amphenol.

This section illustrates the following port blades:

- The FC8-32E port blade.
- The FC8-48E port blade.
- The FC8-64 port blade.
- The FC16-32 port blade.
- The FC16-48 port blade.
- The FC16-64 port blade.
- The FS8-18 encryption blade.
- The FX8-24 extension blade.
- The FCOE10-24 application blade.

FIGURE 7 FC8-32E port blade

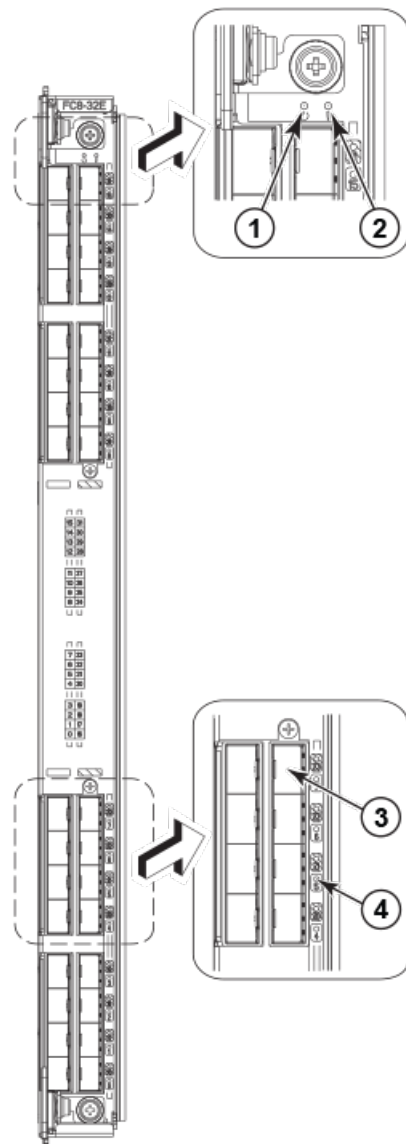

1. Power LED
2. Status LED

- 3. Fibre Channel port
- 4. Port status LED

FIGURE 8 FC8-48E port blade

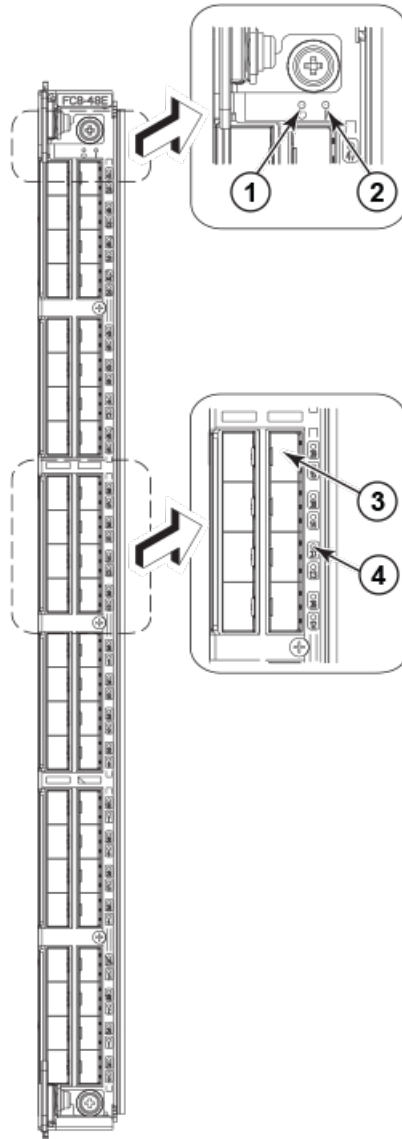

- 1. Power LED
- 2. Status LED
- 3. Fibre Channel port
- 4. Port status LED

FIGURE 9 FC8-64 port blade

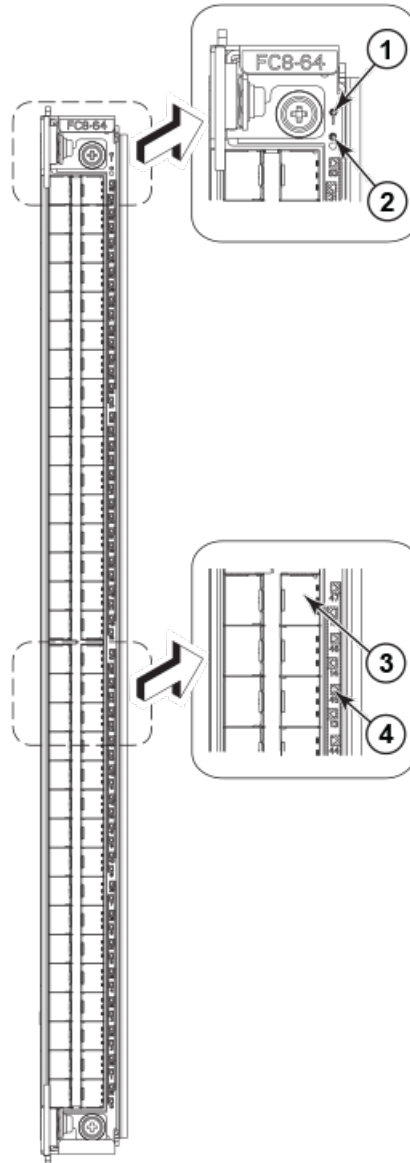

- 1. Status LED
- 2. Power LED
- 3. Fibre Channel port
- 4. Port status LED

FIGURE 10 FC16-32 port blade

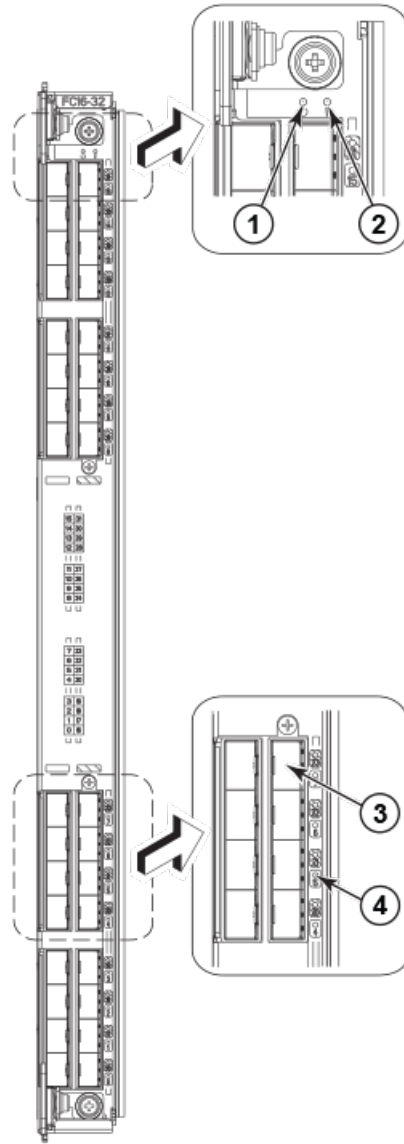

- 1. Power LED
- 2. Status LED
- 3. Fibre Channel port
- 4. Port status LED

FIGURE 11 FC16-48 port blade

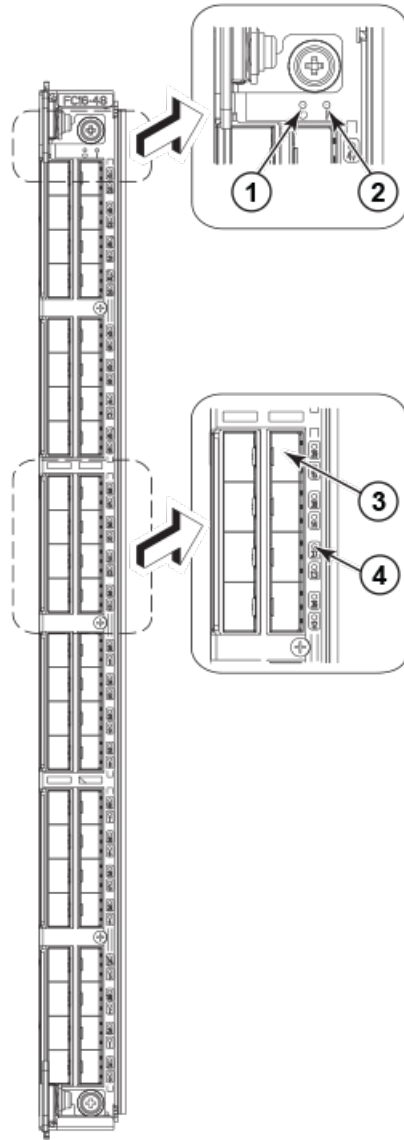

- 1. Power LED
- 2. Status LED
- 3. Fibre Channel port
- 4. Port status LED

FIGURE 12 FC16-64 port blade

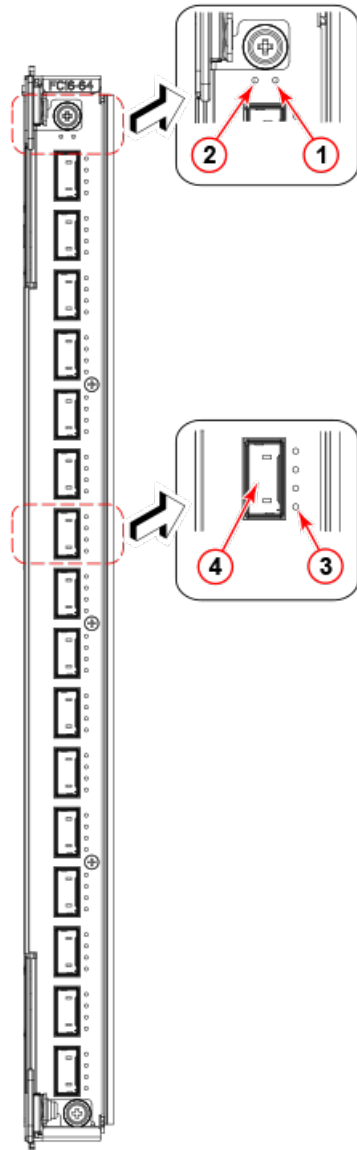

1. Blade Power LED
2. Blade Status LED
3. Port status LED for FC port 36
4. QSFP port 9; FC ports 36-39 (bottom to up)

FIGURE 13 FS8-18 encryption blade

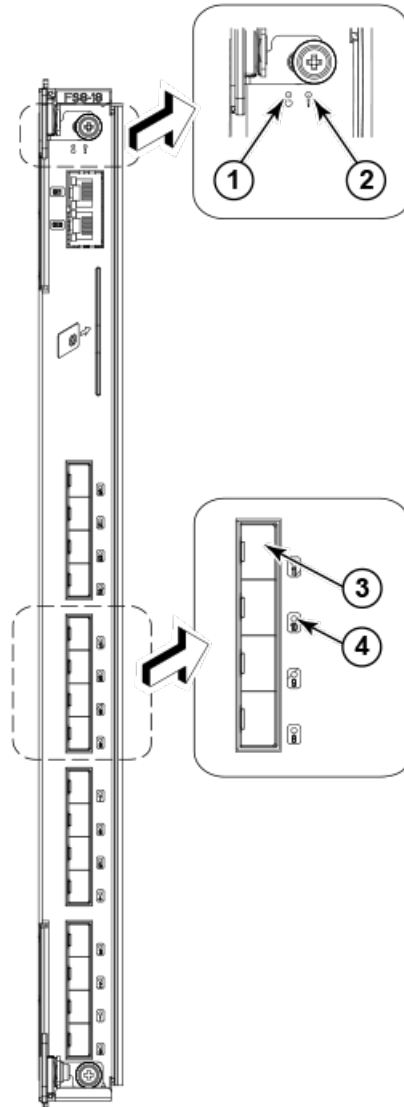

1. Power LED
2. Status LED
3. Fibre Channel port
4. Port status LED

FIGURE 14 FX8-24 extension blade

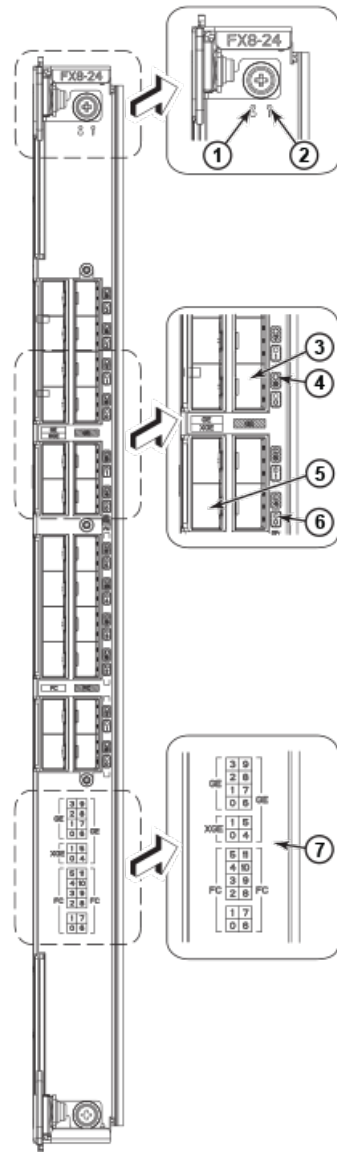

1. Power LED
2. Status LED
3. GbE port 6
4. GbE port 6 LED
5. 10-GbE port 0
6. 10-GbE port 0 LED
7. Port map

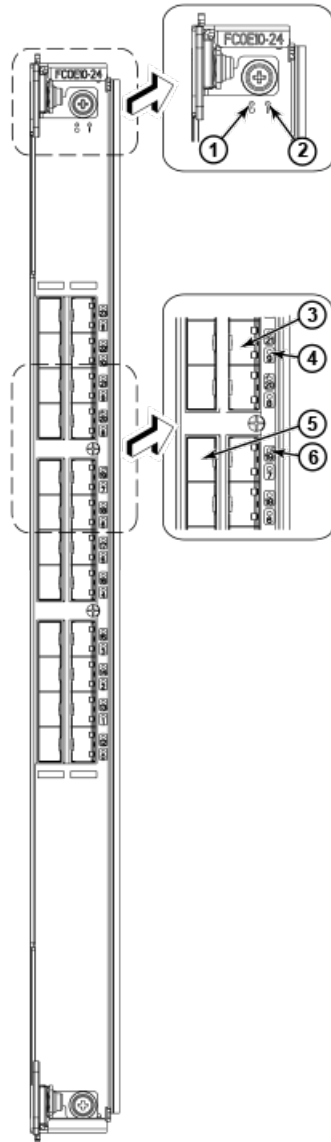
FIGURE 15 FCOE10-24 FCoE blade

1. Power LED10 GbE
2. Status LED
3. 10 GbE FCoE port 9
4. 10 GbE FCoE port 9 LED
5. 10 GbE FCoE port 19
6. 10 GbE FCoE port 19 LED

The following table describes the port and application blade LED patterns and the recommended actions for those patterns.

TABLE 5 Port and application blade LED descriptions



| LED purpose | Color | Status | Recommended action |
|--|--|--|---|
| Power LED  | Steady green | Blade is enabled. | No action required. |
| | No light (LED is off) | Blade is not powered on. | Ensure that the blade is firmly seated and either the thumbscrew is fully engaged or the slider is pushed up and the ejectors are fully engaged. |
| Status LED  | No light (LED is off) | Blade is either healthy or does not have power. | Verify that the power LED is on. |
| | Steady amber | Blade is faulty. | Ensure that the blade is firmly seated and check the status by entering the slotShow command. If LED remains amber, consult the Brocade DCX 8510-8 supplier. |
| | Slow-flashing amber (on 2 seconds, then off 2 seconds) | Blade is not seated correctly or is faulty. | Pull the blade out and reseal it. If LED continues to flash, replace the blade. |
| | Fast-flashing amber (on 1/2 second, then off 1/2 second) | Environmental range exceeded. | Check for out-of-bounds environmental condition and correct it. |
| FC Port Status | No light (LED is off) | Port has no incoming power, or there is no light or signal carrier detected. | Verify that the power LED is on, check the transceiver and cable. |
| | | Polling is in progress. | Allow 60 seconds for polling to complete. |
| | | Connected device is configured in an offline state. | Verify the status of the connected device. |
| | Steady green | Port is online (connected to an external device) but has no traffic. | No action required. |
| | Slow-flashing green (on 1 second, then off 1 second) | Port is online but segmented, indicating a loopback plug or cable or an incompatible switch. | Verify that the correct device is attached to the Brocade DCX 8510-8. |
| | Fast-flashing green (on 1/4 second, then off 1/4 second) | Port is in internal loopback (diagnostic). | No action required. |
| | Flickering green | Port is online, with traffic flowing through port. | No action required. |

TABLE 5 Port and application blade LED descriptions (Continued)

| LED purpose | Color | Status | Recommended action |
|---|--|---|--|
| | Steady amber | Port is receiving light or signal carrier, but it is not online yet. | Reset the port from the workstation using the portEnable or portCfgPersistentEnable command. |
| | Slow-flashing amber (on 2 seconds, then off 2 seconds) | Port is disabled due to diagnostic tests or portDisable or portCfgPersistentEnable command. | Reset the port from the workstation using the portEnable or portCfgPersistentEnable command. |
| | Fast-flashing amber (on 1/2 second, then off 1/2 second) | Transceiver or port is faulty. | Change the transceiver or reset the switch from the workstation. |
| | Alternating green/amber | Port is bypassed. | Reset the port from the workstation using the portEnable or portCfgPersistentEnable command. |
| GbE Port Status (FX8-24) - both 1 GbE and 10 GbE ports | No light (LED is off) | Port has no incoming power, or there is no light or signal carrier detected. | Verify that the power LED is on, check the transceiver and cable. |
| | Steady green | Port is online but has no traffic. | No action required. |
| | Slow-flashing green (on 1 second, then off 1 second) | Beacon. Used to identify specific ports. | No action required. |
| | Flickering green | Port is online, with traffic flowing through port. | No action required. |
| | Fast-flashing amber (on 1/4 second, then off 1/4 second) | Transceiver or port is faulty. | Change the transceiver or reset the switch from the workstation. |

Determining the status of a control processor blade (CP8)

Complete the following steps to determine the status of a control processor blade (CP8)

1. Check the LED indicators on the CP blade. The LED patterns may temporarily change during POST and other diagnostic tests. For information about how to interpret the LED patterns, refer to the following table.
2. Check the port blade status by entering **slotShow** and **haShow**.

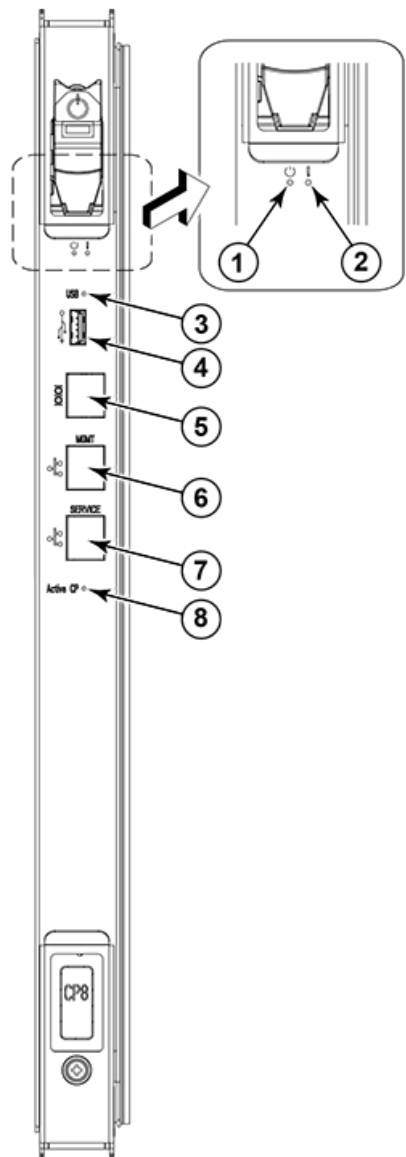

FIGURE 16 Control processor blade (CP8)



1. Power LED
2. Status LED
3. USB LED
4. USB port
5. Console port (Serial)
6. Ethernet port (Mgmt IP)
7. Ethernet port (Service IP)
8. Active CP LED

The following table describes the CP blade LED patterns and the recommended actions for those patterns.

TABLE 6 CP blade LED descriptions

| LED purpose | Color | Status | Recommended action |
|--|--|--|---|
| Power  | Steady green | CP blade is on. | No action required. |
| | No light (LED is off) | CP blade is not on. | Ensure that the blade is firmly seated and has power. |
| Status  | No light (LED is off) | CP blade is either healthy or does not have power. | Verify that the power LED is on. |
| | Steady amber | CP blade is faulty or the switch is still booting. | Ensure that the blade is firmly seated and the switch has completed booting. If LED remains amber, consult the Brocade DCX 8510-8 supplier. |
| | Slow-flashing amber (on 2 seconds, then off 2 seconds) | CP blade is not seated correctly or is faulty. | Pull the blade out and reseal it. If the LED continues to flash, replace the blade. |
| | Fast-flashing amber (on 1/2 second, then off 1/2 second) | Environmental range exceeded. | Check for out-of-bounds environmental condition and correct it. |
| Ethernet Link Status | No light (LED is off) | Either an Ethernet link is not detected, or it does not have incoming power. | Ensure that the blade has power, the Ethernet cable is firmly seated, and the connected device is functioning. |
| | Flickering green/amber | Ethernet link is healthy and traffic is flowing through port. | No action required. |
| Ethernet Link Speed | No light (LED is off) | Ethernet link speed is 10 Mb/s or CP blade does not have incoming power. | Ensure that the CP has power. NOTE: To force a persistent Ethernet link speed, enter the ifModeSet command. |
| | Steady green | Ethernet link speed is 100/1000 Mb/s. | No action required. |
| USB Status | Lamp on | USB stick enabled. | No action required. |
| | Lamp off | USB stick not present or disabled. | No action required. |
| Active CP | Steady blue | Active CP blade. | No action required. |
| | No light (LED is off) | Standby CP blade. | No action required. |

Determining the status of a core switch blade (CR16-8)

Complete the following steps to determine the status of a core switch blade (CR16-8).

1. Check the LED indicators on the core switch blade. The LED patterns may temporarily change during POST and other diagnostic tests. For information about how to interpret the LED patterns, refer to the following table.
2. Check the core switch blade status by entering **slotShow** and **haShow**.

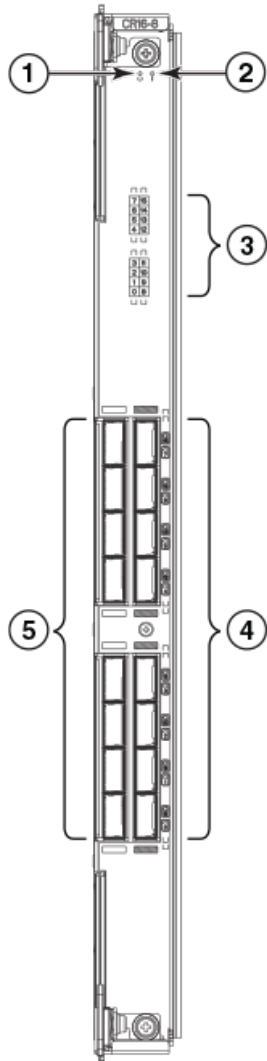

FIGURE 17 Core switch blade (CR16-8)



1. Power LED
2. Status LED
3. QSFP port map and trunking diagram
4. QSFP connectors
5. QSFP connectors

The following table describes the core switch blade LED patterns and the recommended actions for those patterns.

TABLE 7 CR blade LED descriptions

| LED purpose | Color | Status | Recommended action |
|--|--|--|---|
| Power  | Steady green | CR16-8 blade is on. | No action required. |
| | No light (LED is off) | CR16-8 blade is not on. | Ensure that the blade is firmly seated and has power. |
| Status  | No light (LED is off) | CR16-8 blade is either healthy or does not have power. | Verify that the power LED is on. |
| | Steady amber | CR16-8 blade is faulty or the switch is still booting. | Ensure that the blade is firmly seated and the switch has completed booting. If the LED remains amber, consult the Brocade DCX 8510-8 supplier. |
| | Slow-flashing amber (on 2 seconds, then off 2 seconds) | CR16-8 blade is not seated correctly or is faulty. | Pull the blade out and reseal it. If the LED continues to flash, replace the blade. |
| | Fast-flashing amber (on 1/2 second, then off 1/2 second) | Environmental range exceeded. | Check for out-of-bounds environmental condition and correct it. |
| QSFP connector status LED | No light (LED is off) | No QSFP module, all four QSFP ports are disabled | No action needed if the QSFP is not installed or verify that the QSFP is fully inserted. |
| | Steady amber | QSFP module is in, all four ports have no signal/no sync. | Ensure that the cable is properly connected. If the LED remains amber, consult the Brocade DCX 8510-8 supplier. |
| | Blinking amber | Port is disabled or faulted, FC link activity, segmented, loopback mode, also during transition between cable plug in and all four ports online. | Check for console messages or wait for all four ports to come online. |
| | Steady green | QSFP module is in and all ports are online. | No action needed. |

Refer to [Port Numbering Template](#) on page 137 for a map of the ports and a table of external ports to internal ports as shown in the **slotShow** command.

Determining the status of a power supply

Complete the following steps to determine the status of a power supply.

1. Check the LED indicator on the power supply. The LED patterns may temporarily change during POST and other diagnostic tests; for information about how to interpret the LED patterns, refer to the following table. The Brocade DCX 8510-8 has four power supplies. Be sure to check each module.
2. Check the power supply status by entering **psShow**.

The power supply status displays OK, Absent, or Faulty. If a power supply displays absent or faulty, contact the Brocade DCX 8510-8 supplier to order replacement parts. Both physically absent or faulty could also be the result of the power supply not being properly seated or being turned off.

FIGURE 18 Power supply

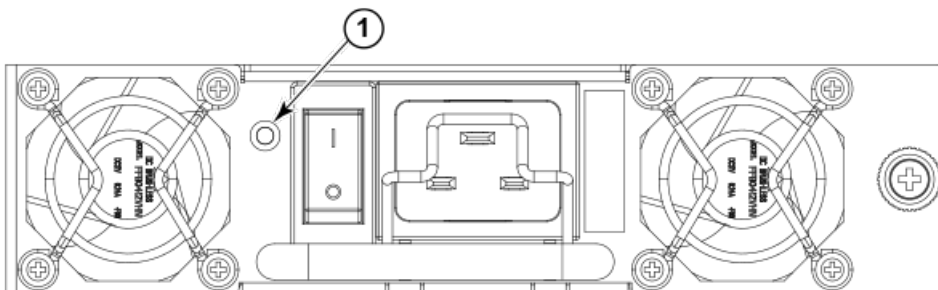

1. Power LED

The following table describes the power supply LED patterns and the recommended actions for those patterns.

TABLE 8 Power supply LED descriptions

| LED purpose | Color | Status | Recommended action |
|---|-----------------------|---|--|
| Power  | No light (LED is off) | Power supply does not have incoming power and is not providing power to the Brocade DCX 8510-8. | Ensure that the power supply is firmly seated, the Brocade DCX 8510-8 has incoming power, both power cables are connected, and AC power switches are on. |
| | Steady green | Power supply has incoming power and is providing power to the Brocade DCX 8510-8. | No action required. |
| | Flashing green | Power supply is about to fail. | Replace the power supply. |

Determining the status of a blower assembly

Complete the following steps to determine the status of a blower assembly.

1. Check the LED indicators on the blower assembly. The LED patterns may temporarily change during POST and other diagnostic tests; for information about how to interpret the LED patterns, refer to following table. The Brocade DCX 8510-8 has three blowers. Be sure to check each module.
2. Check the blower assembly status using the **fanShow** command.

The status for each blower assembly displays OK, Absent, or Faulty. The RPM of each fan in the assembly is also provided. If a blower assembly displays absent or faulty, contact the Brocade DCX

8510-8 supplier to order replacement parts. Both physically absent or faulty could also be the result of the power supply not being properly seated.

FIGURE 19 Blower assembly

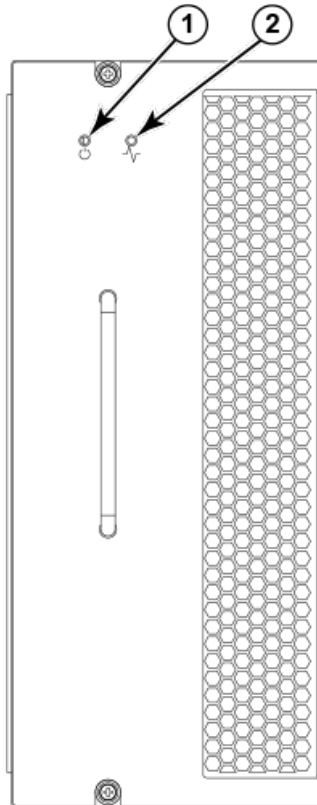

1. Power LED
2. Fault LED

The following table describes the LED patterns for the blower assembly.

TABLE 9 Blower assembly LED descriptions



| LED purpose | Color | Status | Recommended action |
|---|--|---|---|
| Power  | No light (LED is off) | Blower assembly does not have power. | Ensure that the blower assembly is firmly seated and has power. |
| | Steady green | Blower assembly has power. | No action required. |
| Fault  | No light (LED is off) | Blower assembly is either healthy or does not have power. | Ensure that the blower assembly has power. |
| | Steady amber | Blower assembly has a failure (full or partial). | Replace the blower assembly. |
| | Slow-flashing amber (on 2 seconds, then off 2 seconds) | Blower assembly is not seated correctly or is faulty. | Pull the unit out and reseal it. If the LED continues to flash, replace the unit. |

TABLE 9 Blower assembly LED descriptions (Continued)

| LED purpose | Color | Status | Recommended action |
|-------------|--|-------------------------------|--|
| | Flashing amber (on 1/2 second, then off 3.5 seconds) | Fan is disabled. | Run the fanEnable command to enable the fan. |
| | Fast-flashing amber (on 1/2 second, then off 1/2 second) | Environmental range exceeded. | Check for out-of-bounds environmental condition, resolve any problems, and reseal the unit. If the LED continues to flash, replace the unit. |

Determining the status of a WWN card

Complete the following steps to determine the status of a WWN card.

NOTE

The WWN bezel (logo plate) covers the WWN cards.

1. Enter the **chassisShow** command to display information about the WWN card. (WWN units correspond to information specific to the WWN card.) Error messages that may indicate problems with a WWN card are summarized in the following table.

TABLE 10 Messages that may indicate WWN card failure

| Type of message | Sample error message |
|--|---|
| WWN unit fails its field-replaceable unit (FRU) header access. | 0x24c (fabos): Switch: switchname, error EM-I2C_TIMEOUT, 2, WWN 1 I2C timed out: state 0x4 |
| WWN unit fails to power on. | <timestamp>, [EM-1004], <sequence-number>,, CRITICAL, <system-name>, WWN # failed to power on or <timestamp>, [EM-1043], <sequence-number>,, WARNING, <system-name>, Can't power <FRU Id> <state (on or off)>. |
| WWN unit is being faulted. | 0x24c (fabos): Switch: switchname, Critical EM-WWN_UNKNOWN, 1, Unknown WWN #2 is being faulted or <timestamp>, [EM-1003], 40, SLOT 7 FFDC CHASSIS, CRITICAL, Brocade_DCX, WWN 2 has unknown hardware identifier: FRU faulted or <timestamp>, [EM-1034], <sequence-number>,, ERROR, <system-name>, WWN # set to faulty, rc=<return code> |
| WWN unit is not present or is not accessible. | 0x24c (fabos): Switch: switchname, Error EM-WWN_ABSENT, 2, WWN #1 not present or <timestamp>, [EM-1036], <sequence-number>,, WARNING, <system-name>, <FRU Id> is not accessible. |
| Writing to the FRU history log (hilSetFruHistory) has failed. | 0x24c (fabos): Switch: switchname, Error EM-HIL_FAIL, 2, HIL Error: hilSetFruHistory failed, rc=-3 for SLOT 3 |
| WWN unit insertion was detected. | <timestamp>, [EM-1049], <sequence-number>,, INFO, <system-name>, FRU WWN # insertion detected. |

TABLE 10 Messages that may indicate WWN card failure (Continued)

| Type of message | Sample error message |
|--------------------------------|--|
| WWN unit removal was detected. | <timestamp>, [EM-1050], <sequence-number>,, INFO, <system-name>, FRU WWN # removal detected. |

2. Check the LED indicators on the WWN bezel and verify that they reflect the actual status of the components. The WWN bezel covers the WWN cards and allows its LEDs to shine through. The LEDs on the WWN bezel provide a consolidated view of the port, CP, and CR blade status.

Refer to the following table for a description of the WWN card LED patterns and the recommended actions for those patterns.

TABLE 11 WWN LED patterns for DCX and DCX 8510-8

| LED location/purpose | Color | Status | Recommended action |
|-------------------------------|-----------------------|-----------------|---------------------|
| Port blade/CP/CR blade power | Steady green | Power is okay. | No action required. |
| Port blade/CP/CR blade status | Steady amber | Card is faulty. | Check card. |
| | No light (LED is off) | Card is okay. | No action required. |

NOTE: If a blade slot has a filler panel installed, the corresponding LEDs on the WWN card do not light up.

NOTE: If a status LED on the WWN bezel flashes, the power LED on the WWN bezel also flashes, for increased visibility.

The following figure displays the WWN bezel (logo plate). The WWN cards are under the bezel.

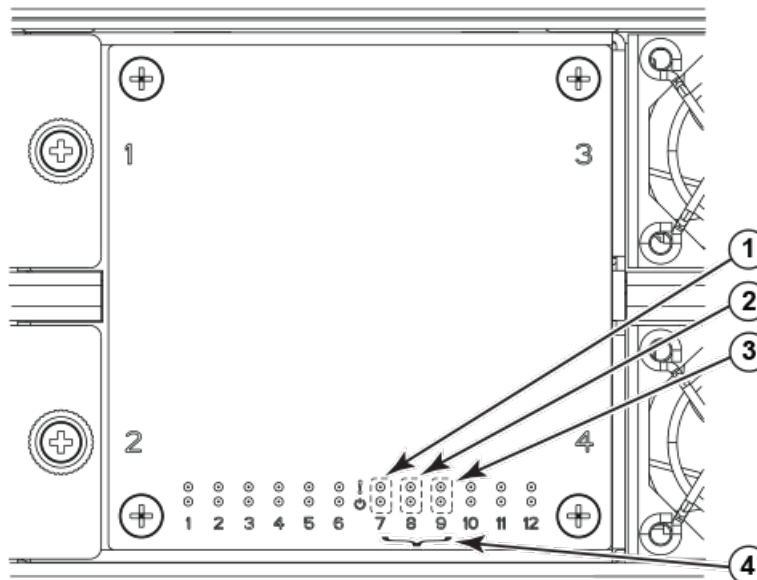
FIGURE 20 WWN bezel (logo plate) with LEDs for DCX and DCX 8510-8

1. CP blade Status (above) and Power (below) LEDs
2. CR blade Status (above) and Power (below) LEDs

3. Port blade Status (above) and Power (below) LEDs
4. Slot numbers

Removal and Replacement Procedures

- Introduction..... 75
- ESD precautions..... 75
- Chassis door removal and replacement..... 76
- Cable management comb removal and replacement..... 77
- Port, application, and encryption blade removal and replacement..... 78
- Blade filler panel removal and replacement..... 82
- Control processor blade (CP8) removal and replacement..... 84
- Core switch blade (CR16-8) removal and replacement..... 92
- Power supply removal and replacement..... 95
- Blower assembly removal and replacement..... 98
- WWN card removal and replacement..... 99
- Transceiver removal and replacement..... 103
- Inter-chassis link (ICL) cable removal and replacement..... 108
- Brocade DCX 8510-8 chassis removal and replacement..... 113

Introduction

NOTE

Read the safety notices before servicing [Caution and Danger Notices](#).

The field-replaceable units (FRUs) in the Brocade DCX 8510-8 can be removed and replaced without special tools. The Brocade DCX 8510-8 can continue operating during many of the FRU replacements if the conditions specified in the procedures are followed.

The following sections contain FRU removal and replacement procedures (RRPs).

ESD precautions

The Brocade DCX 8510-8 contains ESD-sensitive FRUs. When working with any Brocade DCX 8510-8 FRU, use correct electrostatic discharge (ESD) procedures.

- Wear a wrist grounding strap connected to chassis ground (if the Brocade DCX 8510-8 is plugged in) or a bench ground.
- Store ESD-sensitive components in antistatic packaging.



DANGER

For safety reasons, the ESD wrist strap should contain a series 1 megaohm resistor.



CAUTION

Static electricity can damage the chassis and other electronic devices. To avoid damage, keep static-sensitive devices in their static-protective packages until you are ready to install them.

Chassis door removal and replacement

NOTE

The chassis door must be installed to ensure the Brocade DCX 8510-8 meets EMI and other regulatory certifications.

Time and items required

The replacement procedure for the chassis door takes less than five minutes.

Removing a chassis door

Support the door to prevent it from falling. Pull and remove the door. It will pop off the ball studs.

FIGURE 21 Removal and replacement of the chassis door

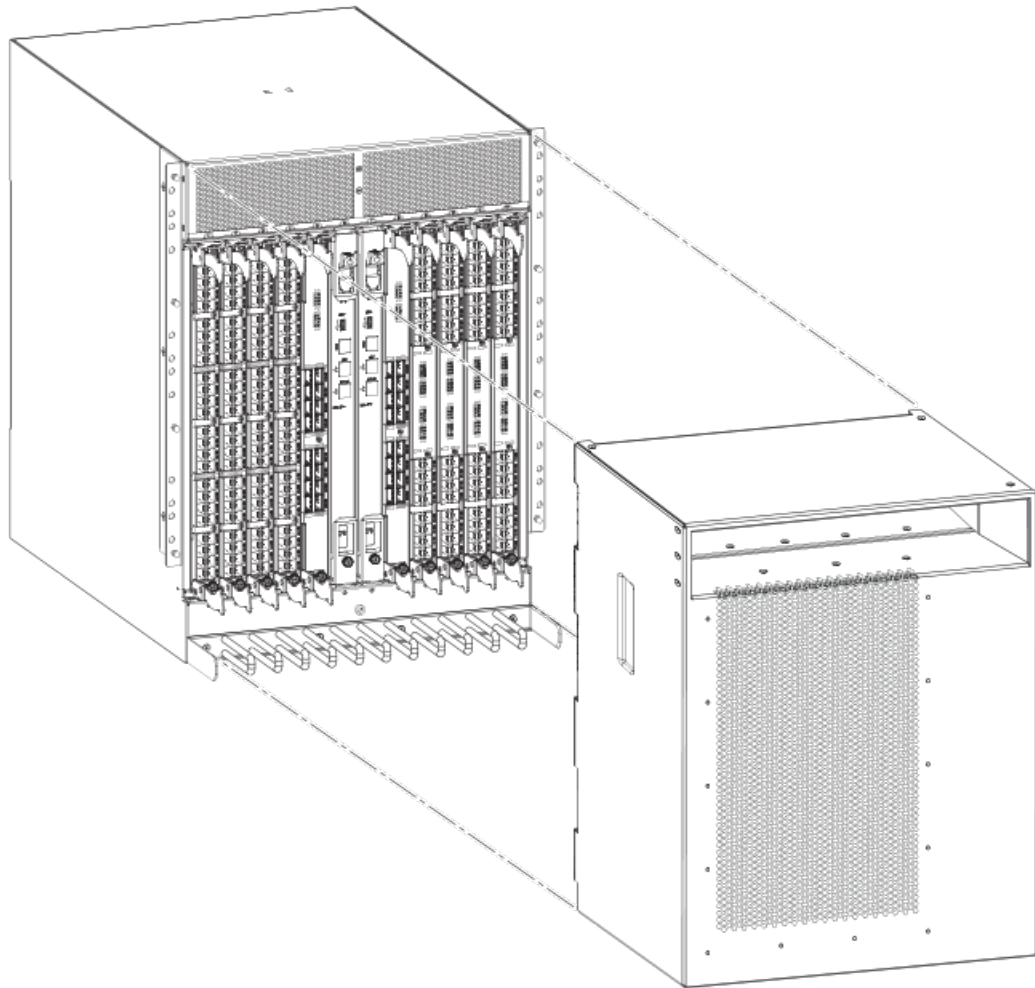

Replacing a chassis door

Complete the following steps to reinstall the door.

1. Align the holes in the door with the ball studs on the chassis.
2. Push the door into place. It will snap onto the studs.

Cable management comb removal and replacement

The Brocade DCX 8510-8 can continue to operate during the replacement of the cable management comb.

Time and items required

The replacement procedure for the cable management comb takes less than five minutes. A #1 Phillips screwdriver is required.

Removing a cable management comb

Complete the following steps to remove the cable management comb.

1. Remove the chassis door.
2. Remove the cables from the cable management comb and rearrange the cables around the comb.
3. Unscrew and save the four (4) screws holding the comb to the chassis. Support the comb to prevent it from falling.
4. Remove the cable management comb.

FIGURE 22 Removal and replacement of the cable management comb

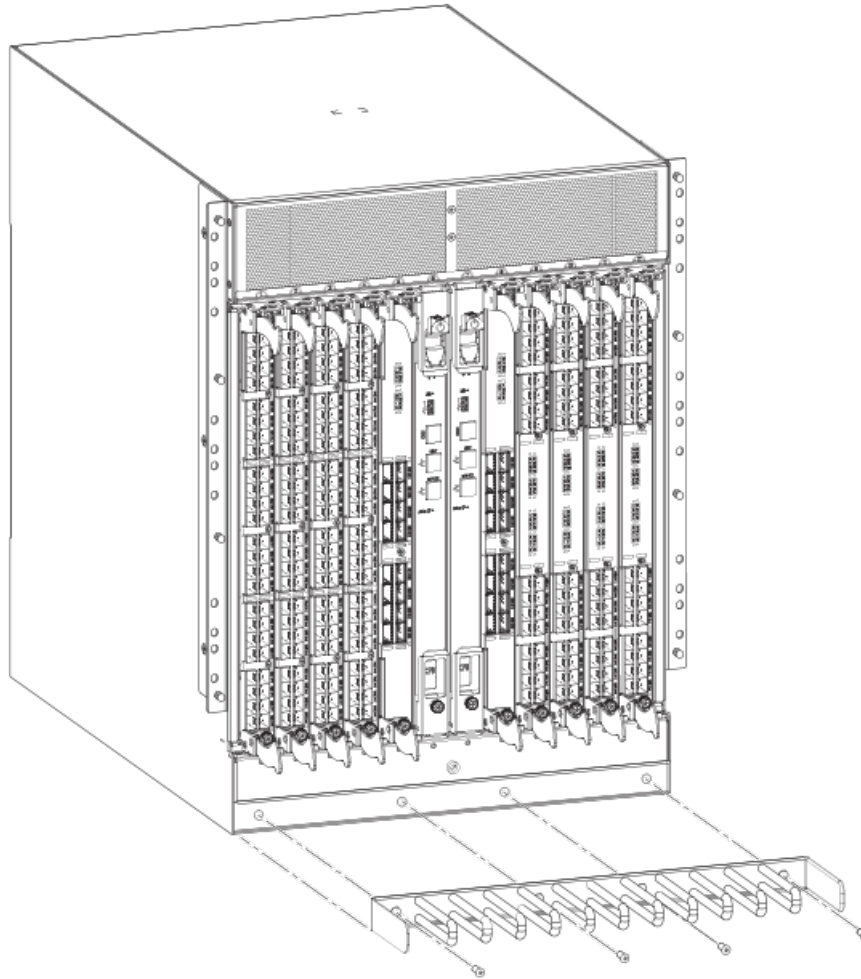

Replacing a cable management comb

Complete the following steps to replace the cable management comb.

1. Position and tighten the four (4) screws to secure the cable management comb to the chassis.
2. Arrange the cables along the cable management comb.
3. Replace the chassis door.

Port, application, and encryption blade removal and replacement

This section describes how to remove and replace port, application, and encryption blades. It does not cover the core (CR) blades or the control processor (CP) blades.

**CAUTION**

If you do not install a module or a power supply in a slot, you must keep the slot filler panel in place. If you run the chassis with an uncovered slot, the system will overheat.

Slots are numbered from 1 through 12, from left to right when facing the port side of the Brocade DCX 8510-8. Port, application, and encryption blades can be installed in slots 1 through 4 and 9 through 12.

This section is applicable for all the following port, application, and encryption blades supported on the DCX 8510 chassis:

| Blade | DCX | DCX-4S | DCX 8510-4 | DCX 8510-8 |
|--|-----------|-----------|------------|----------------------------|
| FC8-32E port blade | No | No | Supported | Supported |
| FC8-48E port blade | No | No | Supported | Supported |
| FC8-64 port blade | Supported | Supported | Supported | Supported |
| FC16-32 port blade | No | No | Supported | Supported |
| FC16-48 port blade | No | No | Supported | Supported |
| FC16-64 port blade | No | No | Supported | Supported |
| FCOE10-24 application blade | Supported | Supported | No | Supported (only in slot 1) |
| NOTE Not supported in the same chassis with FC8-48E, FC8-64, FC16-48, FC16-64, FS8-18, or FX8-24 blades. | | | | |
| FS8-18 encryption blade | Supported | Supported | Supported | Supported |
| FX8-24 application blade | Supported | Supported | Supported | Supported |

NOTE

For complete list of limitations on the FCOE10-24 application blade, refer to the Fabric OS Release Notes.

Time and items required

The replacement procedure for each blade takes less than 10 minutes. Removing and restoring transceivers and cables may take longer depending on how many must be changed. The following items are required for the blade and filler panel replacement:

- Electrostatic discharge (ESD) grounding strap
- Workstation computer
- Replacement blade or filler panel
- #2 Phillips screwdriver

- Small form-factor pluggable (SFP+, mSFP, or QSFP) transceivers (as needed)
- Optical and copper cables (as needed)

NOTE

For information about the transceivers that are qualified for the Brocade chassis, go to <http://www.brocade.com/downloads/documents/matrices/sfp-matrix-mx.pdf>.

Removing a blade

Complete the following steps to remove a blade.

Follow electrostatic discharge (ESD) precautions when removing a blade. Wear a wrist grounding strap connected to chassis ground (if the Brocade DCX 8510-8 is plugged in) or a bench ground.



DANGER

For safety reasons, the ESD wrist strap should contain a series 1 megaohm resistor.

NOTE

Before removing any cables from a blade, note the cable order (identify each cable by its physical port). It is a good practice to keep a table of cable to port mapping.

NOTE

If multiple blades are being replaced, replace one blade at a time.

This procedure is applicable for all the following port, application, and encryption blades supported on the Brocade DCX 8510-8.

1. Remove the chassis door.
2. Check the power LED, status LED, and port status LED to identify any possible problems. A failed port or application blade can be identified by inspecting the LEDs on the front panel of each blade.
3. Establish a Telnet or console session.

Before replacing a blade, establish a Telnet or console connection to determine a failure and verify operation after replacement. Use the **switchShow** command to view the status of the blades.
4. Check for adequate cable slack. Ensure there is plenty of cable slack to remove a blade without cable obstruction.
5. Ensure that the part number on the unit being replaced matches the replacement part number. The **chassisShow** command displays information about the blades, including part numbers (xx-xxxxxx-xx), serial numbers, and additional status.
6. Ensure that traffic is not flowing through the blade (port status LED should be off) prior to disconnecting cables.
7. Ensure that traffic is not flowing through the blade.
8. Disconnect all cables and transceivers from the blade. For mSFP transceivers (FC8-64 only), it is recommended that you use the pull tab to remove the transceiver from the blade.
9. Unscrew the two thumbscrews from the ejectors on the blade using the Phillips screwdriver. Unscrew the top thumbscrew until it pops out. This initiates a hot-swap request.
- 10 Wait for the power LED to turn off in response to the hot-swap request before removing the blade.

11. Open the ejectors by rotating them toward the center of the blade face. Pull the blade out of the chassis using the ejectors.

12. If the blade is not being replaced by another blade, install a filler panel.

FIGURE 23 Removal and replacement of the port, application, and encryption blades (FC16-48 port blade shown)

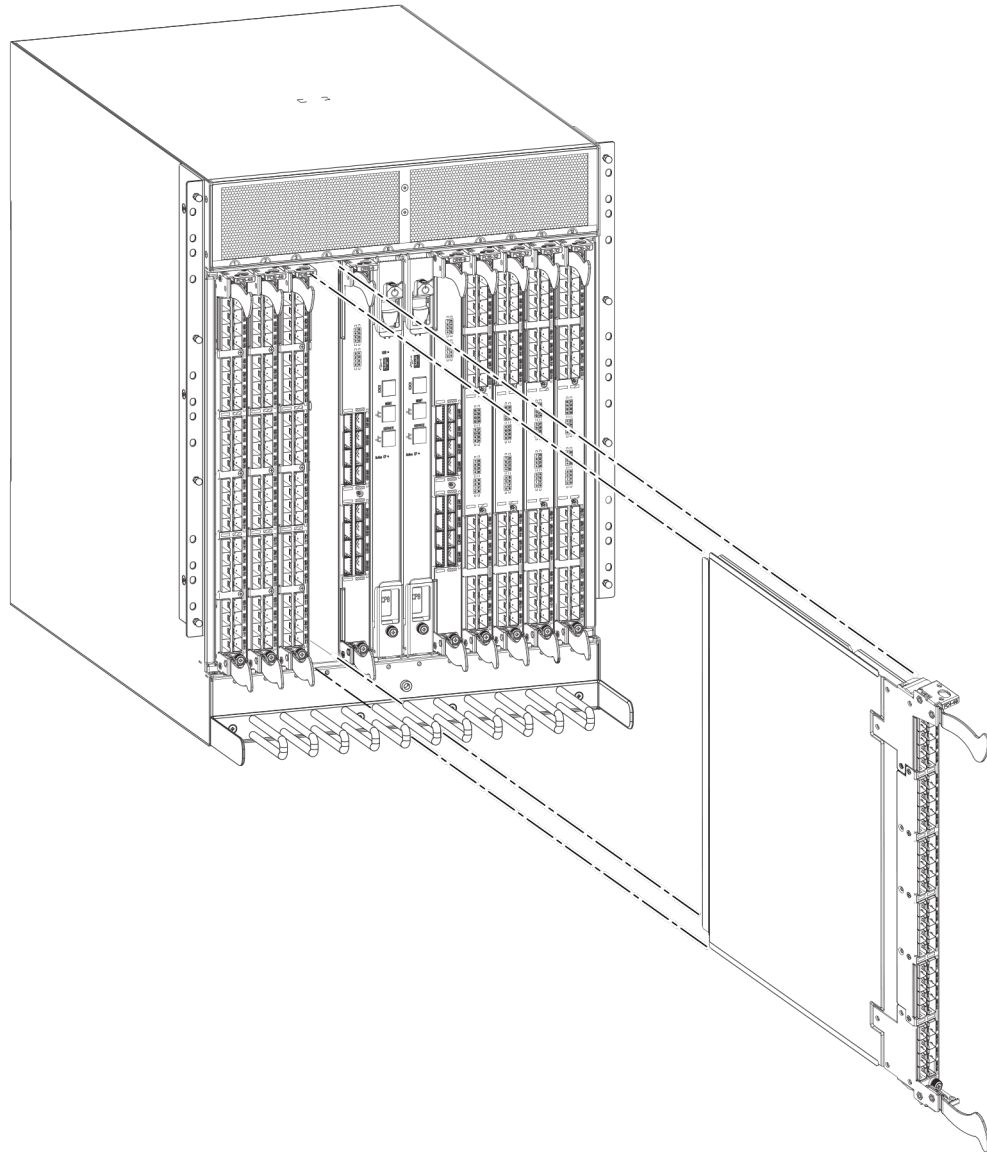

Replacing a blade

Complete this procedure to replace a blade.

Follow electrostatic discharge (ESD) precautions when replacing a blade. Wear a wrist grounding strap connected to chassis ground (if the Brocade DCX 8510-8 is plugged in) or a bench ground.



DANGER

For safety reasons, the ESD wrist strap should contain a series 1 megaohm resistor.

NOTE

An FA4-18i application blade and the Brocade DCX 8510-8 must have the same version of firmware. To upgrade firmware versions, refer to the *Fabric OS Administrator's Guide*.

1. Orient the blade so that the ports are at the front of the chassis and the flat side of the blade is on the left.
2. Open the ejectors by rotating them toward the center of the blade face, align the flat side of the blade inside the top and bottom rail guides in the slot, and slide the blade into the slot until it is firmly seated.
3. Close the ejectors by rotating them away from the center of the blade. The levering action of the ejectors seats the blade in the slot.
4. Tighten the thumbscrews using the Phillips screwdriver.
5. Verify that the power LED on the port blade is displaying a steady green light. If it does not turn on, ensure that the blade is firmly seated.
6. Verify the Status LED on the blade. The status LED will show amber until POST completes for the blade and then display green. If the LED remains amber, the board may not be properly seated in the backplane or the board may be faulty.
7. Install the transceivers and cables in the blade. For mSFP (**FC8-64** port blade only) and QSFP (**FC16-64** port blade only) transceivers, it is recommended that you install the cables in the transceivers before installing the transceivers in the blade.
8. Group and route the cables through the cable management comb.
9. Replace the chassis door.

Blade filler panel removal and replacement

This section describes how to remove and replace blade filler panels.

NOTE

Some filler panels have two thumbscrews and some have only one. Be sure to unscrew or tighten both if you are using the two-screw version.

Removing a filler panel

Complete the following steps to remove a filler panel from the chassis.



CAUTION

If you do not install a module or a power supply in a slot, you must keep the slot filler panel in place. If you run the chassis with an uncovered slot, the system will overheat.

1. Remove the chassis door.
2. Unscrew the thumbscrews on the panel using the Phillips screwdriver.
3. Using the tabs, pull the filler panel out of the chassis.

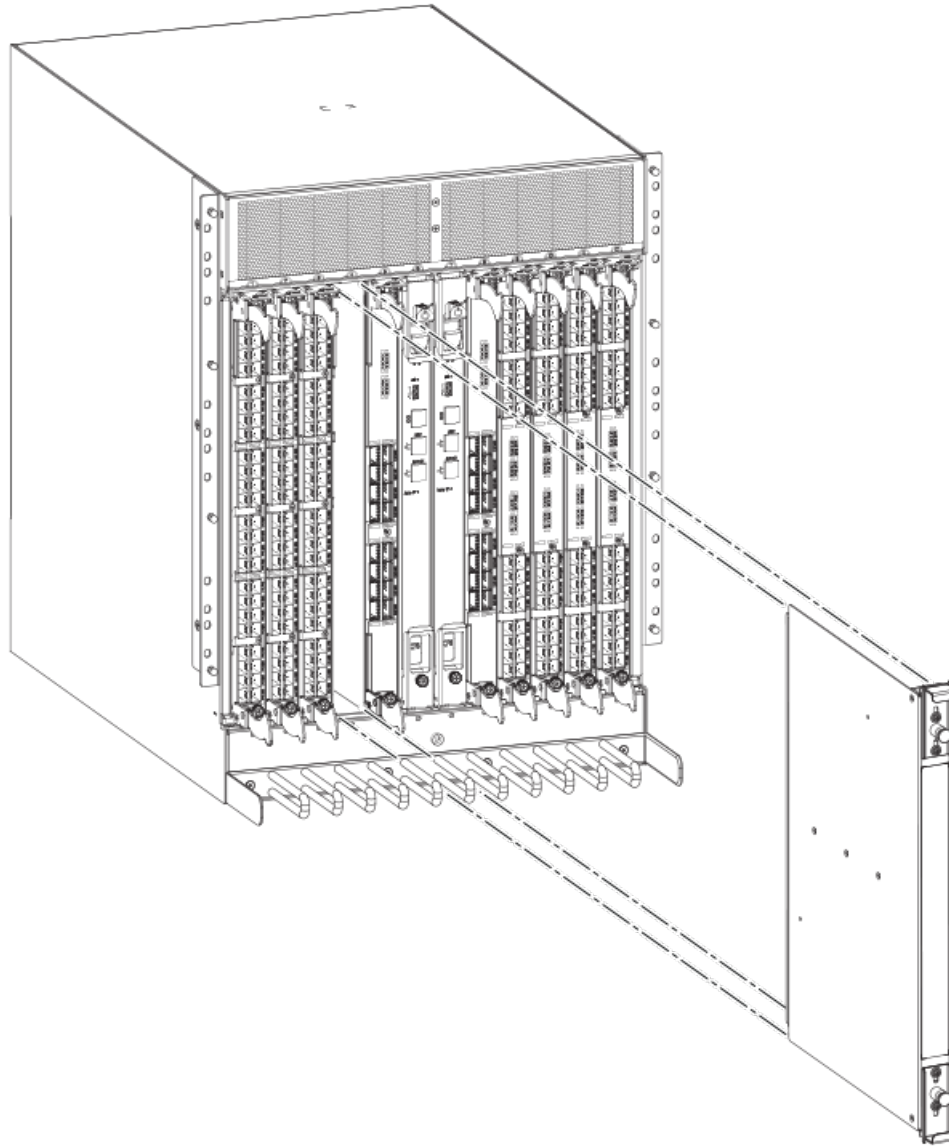
FIGURE 24 Removal and replacement of the blade filler panel

Replacing a filler panel

Do not leave a slot empty. This will adversely affect cooling of the chassis.

1. Orient the filler panel.
2. Slide the filler panel into the slot until it is firmly seated.
3. Tighten the thumbscrews.
4. Replace the chassis door.

Control processor blade (CP8) removal and replacement

This document describes how to remove and replace a control processor (CP8) blade. Each chassis has two CP8 blades. In the DCX 8510-8, they are located in slots 6 and 7.

NOTE

The CP8 blade is compatible only with the Brocade DCX Backbones (including the DCX 8510 Backbones).

NOTE

The Brocade firmware upgrade policy for CP8 blades specifies testing for the current Fabric OS release and one version earlier. It is possible to upgrade by more than one version, but it is a very specific and detailed process. Read the directions under [Downloading firmware from an FTP server](#) on page 89 or [Downloading firmware from a USB device](#) on page 90 carefully.

NOTE

If the new CP blade does not have the same firmware as the active CP blade, the new blade must be upgraded to the same firmware version. You can determine the firmware version on the replacement blade and perform a firmware upgrade if necessary after inserting the blade in the chassis, but you must disable high availability (HA) before inserting the new blade. If the new CP blade is severely down-level, a very specific procedure must be followed to bring the blade up to the correct firmware version.

Time and items required

The replacement procedure for the CP blade takes approximately 30 minutes. The following items are required for the CP blade replacement:

- Electrostatic discharge (ESD) grounding strap
- Workstation computer
- Serial cable
- IP address of an FTP server for backing up the Brocade DCX 8510-8 configuration
- #2 Phillips screwdriver
- Replacement Brocade DCX 8510-8 control processor blade (CP8)

If you are upgrading through multiple versions of the Fabric OS, consult the [Verifying operation of the new CP blade](#) table to see which intermediate versions of the Fabric OS you might need. Plan carefully and for extra time if this is your situation.

Faulty CP blade indicators

Confirm that you need to replace the CP blade. The following events may indicate that a CP blade is faulty:

- The status LED on the CP blade is lit steady amber, or the power LED is not lit.
- The CP blade does not respond to Telnet commands, or the serial console is not available.
- The **slotShow** command does not show that the CP blade is enabled.

- The **haShow** command indicates an error.
- The clock is inaccurate, or the CP blade does not boot up or shut down normally.
- Any of the following messages display in the error log:
 - "Slot unknown" message relating to a CP slot
 - CP blade errors or I2C timeouts
 - FRU: FRU_FAULTY messages for a CP blade
 - Configuration loader messages or "Sys PCI config" messages
 - Generic system driver messages ("FABSYS")
 - Platform system driver messages ("Platform")
 - EM messages that indicate a problem with a CP blade
 - Function fail messages for the CP master

For more information about error messages, refer to the *Fabric OS Message Reference*.

Recording critical Brocade DCX 8510-8 information

Back up the backbone configuration before you replace a CP blade. Refer to the *Fabric OS Administrator's Guide* for backup information.

NOTE

The following instructions reference specific slot numbers. These numbers will be different between the DCX 8510-8/DCX and the DCX 8510-4/DCX-4S chassis.

1. Connect to the chassis and log in as **admin**, using a serial console connection.
2. Enter **haShow** to determine which CP blade is active. The following example is from a DCX chassis.

```
DCX_124:admin> haShow
Local CP (Slot 7, CP1) : Active
Remote CP (Slot 6, CP0) : Standby, Healthy
HA Enabled, Heartbeat Up, HA State Synchronized
```

3. Enter all remaining commands from the serial console for the active CP blade, unless otherwise indicated. For more information about commands, refer to the *Fabric OS Command Reference*.
4. If the active CP blade is faulted, automatic fail over to the standby CP blade should have occurred. Confirm that the standby CP blade is active and power off the faulted CP blade, log in to the standby CP blade, and skip to step 7.

If automatic failover has not occurred, manually failover the faulty blade by moving the slider to the off position (down in the DCX 8510-8). Then power off the faulted blade, log in to the standby CP blade, and skip to step 7.

5. If both CP blades are healthy and you want to replace the standby CP blade, log in to the active CP blade and skip to step 7.
6. If both CP blades are healthy and you want to replace the active CP blade, log in to the active CP blade and run the following steps:
 - a) Run the **haFailover** command to make the standby CP blade the active blade. The currently active CP blade becomes the standby blade. Wait until the status LED on the currently active CP blade is no longer lit.
 - b) Confirm the completion of the failover by running the **haShow** command.
 - c) Log in to the new active CP blade.
7. Run **firmwareShow** to note the firmware version of the active CP blade.

The following example shows the results of the **firmwareshow** command when the firmware versions on the two CP blades are not the same. Note the warning message at the end of the output.

```
DCX_120:root> firmwareshow
Slot Name      Appl      Primary/Secondary Versions      Status
-----
 6 CP0         FOS       v6.4.0a
                v6.4.0a
 7 CP1         FOS       v7.0.0
                v7.0.0
WARNING: The local CP and remote CP have different versions
of firmware, please retry firmwaredownload command.
DCX_120:root>
```

8. Run **haDisable** from the active CP blade to prevent failover or communication between the CP blades during the replacement.
9. Use the **configUpload** command to upload the backbone configuration to a specified FTP server. Enter information at the prompts.
 - a) Run the **fosconfig --show** command to determine if virtual fabrics are enabled. If so, run the **configupload -vf** command. This command uploads the Brocade DCX 8510-8 virtual fabric data.
 - b) If virtual fabrics are not enabled, run the **configupload** command. This command uploads the Brocade DCX 8510-8 configuration.

Removing a control processor blade (CP8)

The chassis continues to operate while a CP blade is being replaced if the redundant CP blade is active and a failover does not occur. You can prevent failover by entering the **haDisable** command.

Complete the following steps to remove a CP8 control blade.

1. Remove the chassis door.
2. Log in to the active CP as the admin user. You can use a serial cable or Telnet, Web Tools, or Fabric Manager. Determine which CP is active using the **haShow** command or view the active LED on the front of the CP.
3. If the faulty CP is the active CP, issue the **haFailover** command. Wait until the failover has completed. Use the **haShow** command to verify the CPs are synchronized and the failover is complete.

Depending on the nature of the CP failure, it is possible that the **haFailover** command may not work. Proceed to the next step anyway.
4. Enter the **haDisable** command. This is required before physically removing and replacing a CP blade.
5. Power off the blade by sliding the slider switch in the top ejector down to the off position. Do not eject the blade until the power LED is off and you have completed the next two steps.
6. Disconnect all cables from the faulty (standby) CP.
7. Unscrew the thumbscrew from both ejectors using the Phillips screwdriver.
8. Lever open both ejector handles simultaneously to approximately 45 degrees and pull the CP blade out of the chassis.

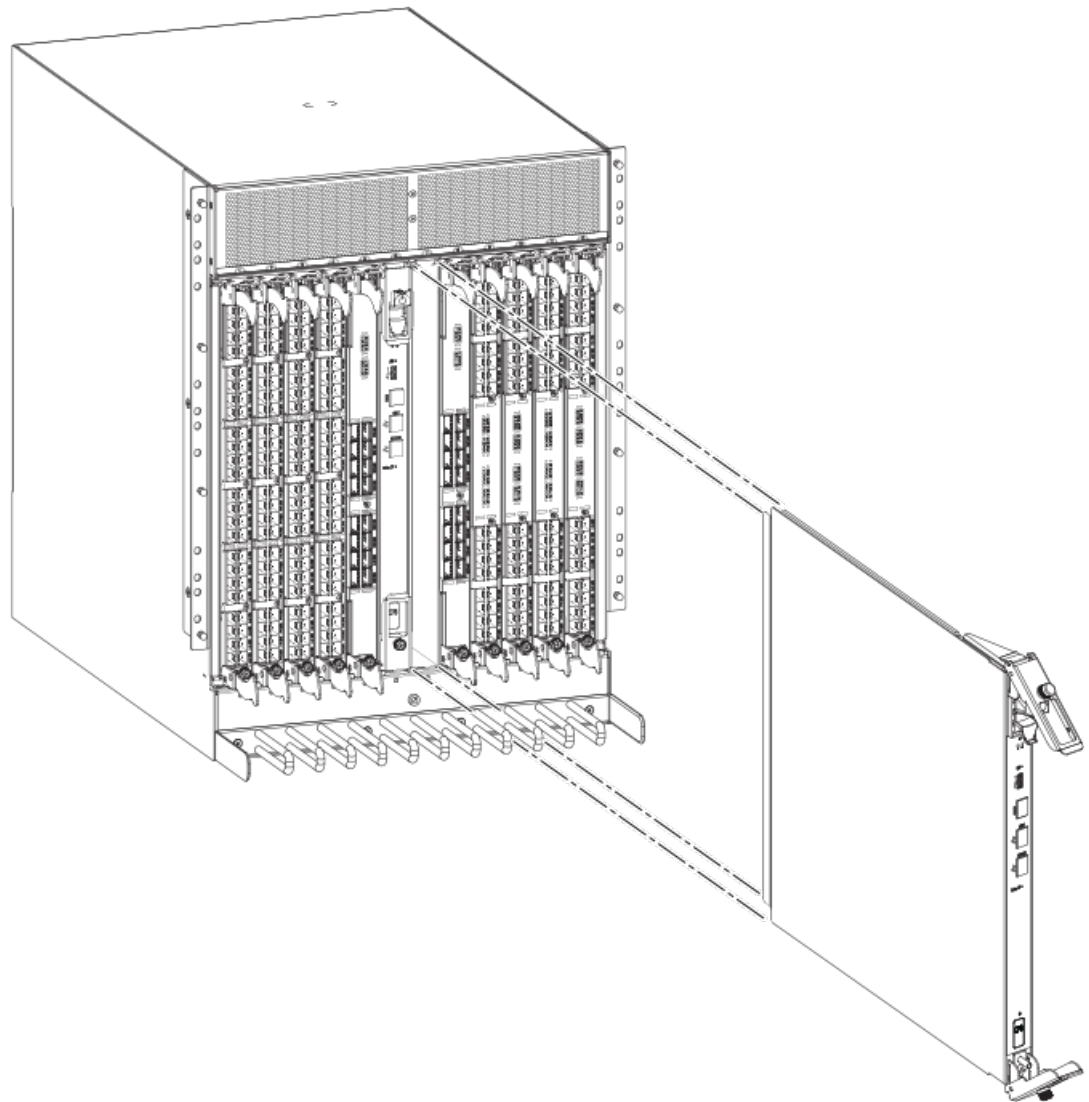
FIGURE 25 Removal and replacement of the control processor blade (CP8)

Replacing a control processor blade (CP8)

NOTE

Read all of the instructions for replacing the CP blade before beginning the procedure. Use the same version of Fabric OS on both CP blades. Using different versions is not supported and may cause malfunctioning. If the replacement CP blade has a different version of Fabric OS, bring both blades to the same firmware version. Once you have installed the replacement CP blade, determine the version of firmware on the replacement CP blade and upgrade it if necessary.

Complete the following steps to remove a CP8 control blade.

1. Open the ejector handles to approximately 45 degrees. Orient the CP blade so that the handles are toward you and the flat metal side is on your left.
2. Align the flat metal side of the CP blade inside the lower and upper blade guides in the slot. Slide the CP blade into the slot until it is firmly seated.
3. Tighten the thumbscrew inside each handle using the Phillips screwdriver.
4. Turn the CP blade on by sliding the ON/OFF switch in the top handle up, to cover the thumbscrew.
5. Verify that the power LED is green. If not, ensure that the CP blade has power and is firmly seated and that the ejectors are in the locked position.
6. Connect the cables to the new CP blade.
7. Remain logged in to the active CP and continue to [Verifying operation of the new CP blade](#) on page 88.

Verifying operation of the new CP blade

To verify that boot and POST are complete on the new CP blade and that the CP blade has achieved failover redundancy, perform the following steps.

1. Enter **slotShow**. The command output shows the new CP blade as "enabled."
 If the standby CP is unresponsive, you can try unplugging the new CP blade, running **haDisable** on the active CP blade, and plugging the new CP blade back in. At that point, you can repeat step 1 to begin the verification process again.
2. Determine the version by entering **firmwareShow**. If the serial console on the replacement CP blade is connected, issue the **firmwareShow** command there. More information is available through the console.

NOTE

The DCX 8510-8 requires Fabric OS 7.0.0 or later to be recognized. If the firmware on the replacement blade is earlier than 7.0.0 it must be brought up to the version on the active CP blade, which must be at least 7.0.0.

3. If the firmware versions for both CP blades are the same, skip to [Completing the replacement](#) on page 91.

If the firmware version on the replacement blade does not match that on the active CP blade, a warning message appears with the results of the **firmwareshow** command. The results of the **firmwareshow** command may look similar to the following. Note the warning message at the end of the output.

The following example is from a DCX 8510-8 chassis.

```
DCX_xyz:admin> firmwareshow
Slot Name      Appl      Primary/Secondary Versions      Status
-----
 6 CP0         FOS       v7.0.0                          ACTIVE
              v7.0.0
 7 CP1         FOS       v6.3.0a                          STANDBY *
              v6.3.0a

* Local CP
WARNING: The local CP and remote CP have different versions
of firmware, please retry firmwaredownload command.
```

4. You must bring the replacement blade to the same firmware level as the active blade by running the **firmwareDownload -s** command *directly on the replacement blade* to bring it up to the proper level. The **firmwareshow** command results show which slots hold the active and standby (replacement) CP blades.

If you are using an FTP server to download the firmware, skip to [Downloading firmware from an FTP server](#) on page 89.

If you are using a USB device to download the firmware, skip to [Downloading firmware from a USB device](#) on page 90. If the firmware on the standby CP blade is more than one level down from the level on the active CP blade, you must have formatted USB devices for each of the versions you will need to upgrade.

For details on supported upgrade paths and steps to upgrade through multiple versions of Fabric OS, refer to the *Fabric OS Release Notes*, and the *Fabric OS Upgrade Guide*.

Downloading firmware from an FTP server

For this task, refer to [Verifying operation of the new CP blade](#) on page 88 for the correct sequence of upgrading firmware versions to reach your target version.

Complete the following steps to download the firmware from an FTP server.

1. Log in to the standby CP blade as **admin**. If you need to know the IP address of the standby blade, run **ipaddrshow**.

You should remain logged in to the active CP blade in order to monitor it.

2. Run **firmwareDownload -s** to download the firmware to the standby CP blade. The **-s** option also disables the autoreboot, so you will have to manually issue a reboot after the download finishes to initiate **firmwarecommit**. Enter all requested information (use default values).
3. When the download process finishes, run **firmwareDownloadStatus** to verify that the firmware has been updated. The command displays a running account of the progress of the **firmwareDownload** command (if it is still running) until the command has completed. The final message is similar to the following and will appear with a date and time stamp:

```
Slot 6 (CP0, active): Firmwaredownload command has completed successfully. Use
firmwaredownload show to verify the firmware versions.
```

4. On the standby CP blade (the blade for which you just changed the firmware level), run **reboot**. The reboot of the standby CP will initiate a **firmwarecommit** to the secondary partition and log you out.

```
DCX_124:admin> reboot
Broadcast message from root (ttyS0) Fri Jun 18 14:49:45 2010...
The system is going down for reboot NOW !!
INIT: Switching to runlevel: 6
INIT: Sending processes the TERM signal DCX_124:admin> HAMu Heartbeat down, stop
FSS
Unmounting all f##exiting due to signal: 9, pending signals: 0x20000, 0x0
ilesystems.
Please stand by while rebooting the system...
Restarting system.
The system is coming up, please wait...
.
.
.
Fri Jun 18 14:53:13 2010: Doing firmwarecommit now.
Please wait ...
Fri Jun 18 14:55:27 2010: Firmware commit completes successfully.
Validating the filesystem ...
Fri Jun 18 22:36:05 2010: Doing firmwarecommit now.
Please wait ...
Fri Jun 18 22:36:48 2010: Firmware commit completes successfully.
2010/06/18-14:56:50, [SULB-1004], 908, SLOT 7 | CHASSIS, INFO, Brocade_DCX,
Firmwarecommit has completed.
2010/06/18-14:56:50, [SULB-1036], 909, SLOT 7 | CHASSIS, INFO, Brocade_DCX, The
new Version: Fabric OS v6.3.0c
2010/06/18-14:56:50, [SULB-1002], 910, SLOT 7 | CHASSIS, INFO, Brocade_DCX,
Firmwaredownload command has completed successfully.
```

NOTE

The time stamp on the co-CPU may not be in sync with the main CPU on the blade. This is not a cause for concern.

5. Log back in to the standby CP blade and run **firmwareDownloadStatus** on the standby CP blade to validate a successful commit. This may take 10 minutes.
6. If you are upgrading through several levels of the Fabric OS, repeat step 2 through step 5 as often as necessary based on the path outlined in the preceding table. Otherwise, proceed to step 7.
7. Log out of the standby CP blade and log in to the active CP blade.
8. Proceed to [Completing the replacement](#) on page 91.

Downloading firmware from a USB device

For this task, refer to [Verifying operation of the new CP blade](#) on page 88 for the correct sequence of upgrading firmware versions to reach your target version.

Complete the following steps to download the firmware from a USB device.

This section assumes that the new firmware has already been copied onto the USB device. The folder structure on the USB device must be as follows in order to allow the device to be enabled:

- brocade>
 - config
 - firmware
 - firmwareKey
 - support

The firmware folder contains the folder for the specific release you are installing.

1. Insert the USB device into the active CP blade.
2. Attach a serial cable from the PC to the active CP blade.
3. Log in to the active CP blade as **admin** if you are not still logged in and enter **usbStorage -e** to enable the USB device.
4. Remove the serial cable from the active CP blade and attach it to the standby CP blade and log in as **admin**.
5. Run **firmwareDownload -s** to download the firmware to the standby CP blade. The **-s** option also disables the autoreboot, so you will have to manually issue a reboot after the download finishes to initiate **firmwarecommit**. Enter all requested information (use default values).
6. This does not apply to the DCX 8510 models. When the download process finishes, run **firmwareDownloadStatus** to verify that the firmware has been updated. The command displays a running account of the progress of the **firmwareDownload** command until the command has completed. The final message is similar to the following and will appear with a date and time stamp:

```
Slot 6 (CP0, active): Firmwaredownload command has completed successfully. Use
firmwareshow to verify the firmware versions.
```

7. Ensure that you are still logged in to the standby CP blade (the blade for which you just changed the firmware level) and type **reboot**. The reboot of the standby CP will initiate a **firmwarecommit** to the secondary partition and log you out.

```
DCX_124:admin> reboot
Broadcast message from root (ttyS0) Fri Jun 18 14:49:45 2010...
The system is going down for reboot NOW !!
INIT: Switching to runlevel: 6
INIT: Sending processes the TERM signal DCX_124:admin> HAMu Heartbeat down, stop
FSS
Unmounting all f##exiting due to signal: 9, pending signals: 0x20000, 0x0
ileystems.
Please stand by while rebooting the system...
Restarting system.
The system is coming up, please wait...
.
.
.
Fri Jun 18 14:53:13 2010: Doing firmwarecommit now.
Please wait ...
```

```

Fri Jun 18 14:55:27 2010: Firmware commit completes successfully.
Validating the filesystem ...
Fri Jun 18 22:36:05 2010: Doing firmwarecommit now.
Please wait ...
Fri Jun 18 22:36:48 2010: Firmware commit completes successfully.
2010/06/18-14:56:50, [SULB-1004], 908, SLOT 7 | CHASSIS, INFO, Brocade_DCX,
Firmwarecommit has completed.
2010/06/18-14:56:50, [SULB-1036], 909, SLOT 7 | CHASSIS, INFO, Brocade_DCX, The
new Version: Fabric OS v6.3.0c
2010/06/18-14:56:50, [SULB-1002], 910, SLOT 7 | CHASSIS, INFO, Brocade_DCX,
Firmwaredownload command has completed successfully.

```

NOTE

The time stamp on the co-CPU may not be in sync with the main CPU on the blade. This is not a cause for concern.

8. Log back in to the standby CP blade and enter **firmwareDownloadStatus** on the standby CP blade to validate a successful commit. This may take 10 minutes.
9. If you are upgrading through several levels of the Fabric OS, repeat step 5 through step 8 as often as necessary based on the path outlined in the preceding table. Otherwise, proceed to step 10.
10. Log out of the standby CP blade and log in to the active CP blade.
11. Proceed to [Completing the replacement](#) on page 91

Completing the replacement

Complete the following steps to complete the CP8 control blade replacement procedure.

1. Enter **haEnable** to re-enable HA on the active CP blade.

NOTE

For Fabric OS 7.0.0 and later, **haEnable** will cause the standby CP blade to reboot. Wait until POST completes before moving to the next step. POST is complete when the Status LED on the CP blade returns to a steady green state.

2. Enter **haShow** and verify that the command output includes "HA Enabled, Heartbeat Up". If it is not yet enabled, re-enter the command until you have verified that redundancy is achieved.

```

DCX_124:admin> hashow
Local CP (Slot 7, CP1) : Active
Remote CP (Slot 6, CP0) : Standby, Healthy
HA Enabled, Heartbeat Up, HA State Synchronized

```

3. Enter **firmwareShow** to verify that the firmware version has been updated and that the versions are the same on the two CP blades. The slot numbers will be different for the DCX 8510-4 or DCX-4S. (not all slot numbers are shown).

```

DCX_8510:admin> firmwareshow
Slot Name      Appl      Primary/Secondary Versions  Status
-----
 4  FX8-24  FOS      v7.0.0
                    v7.0.0
 6  CP0     FOS      v7.0.0          STANDBY
                    v7.0.0
 7  CP1     FOS      v7.0.0          ACTIVE *
                    v7.0.0
10  FX8-24  FOS      v7.0.0
                    v7.0.0

```

4. Pack the faulty CP blade in the packaging provided with the new CP blade, and contact the switch supplier to determine the return procedure.
5. Replace the chassis door.

If you have one or more application blades in the chassis, the Fabric OS automatically detects mismatches between the active CP firmware and the application blade's firmware and triggers the auto-leveling process. This auto-leveling process automatically updates the application blade firmware to match the active CP. At the end of the auto-leveling process, the active CP and the application blades will run the same version of the firmware.

Core switch blade (CR16-8) removal and replacement

This section describes how to remove and replace a core switch blade (CR16-8). The Brocade DCX 8510-8 has two core switch blades: one in slot 5 and one in slot 8.

Time and items required

The replacement procedure for the core switch blade takes approximately 30 minutes. The following items are required for the core switch blade replacement:

- Electrostatic discharge (ESD) grounding strap
- #2 Phillips screwdriver
- Replacement core switch blade

Faulty core switch blade indicators

Confirm that you need to replace the core switch blade before continuing. The following events may indicate that a core switch blade is faulty:

- The status LED on the core switch blade is lit steady amber, or the power LED is not lit.
- The **slotShow** command does not show that the core switch blade is enabled.
- The **haShow** command indicates an error.
- Any of the following messages display in the error log:
 - "Slot unknown" message relating to a core switch slot
 - Core switch blade errors or I2C timeouts
 - FRU: FRU_FAULTY messages for a core switch blade
 - Configuration loader messages or "Sys PCI config" messages
 - Generic system driver messages ("FABSYS")
 - Platform system driver messages ("Platform")
 - EM messages that indicate a problem with a core switch blade
 - Function fail messages for the core switch master

For more information about error messages, refer to the *Fabric OS Message Reference*.

Removing a core switch blade (CR16-8)

Follow electrostatic discharge (ESD) precautions when removing a blade. Wear a wrist grounding strap connected to chassis ground (if the Brocade DCX 8510-8 is plugged in) or a bench ground.



DANGER

For safety reasons, the ESD wrist strap should contain a series 1 megaohm resistor.

NOTE

The CR16-8 blade is compatible only with the Brocade DCX 8510-8.

NOTE

The Brocade DCX 8510-8 continues to operate while a core switch blade is being replaced.

Complete the following steps to remove the core switch blade.

1. Remove the chassis door.
2. Unscrew the two thumbscrews from the ejectors on the blade using the Phillips screwdriver. Unscrew the top thumbscrew until it pops out. This initiates a hot-swap request.
3. Label and then disconnect cables from the faulty core switch blade.
4. Open the ejectors by rotating them toward the center of the blade face. Pull the blade out of the chassis using the ejectors.

FIGURE 26 Removal and replacement of the core switch blade (CR16-8)

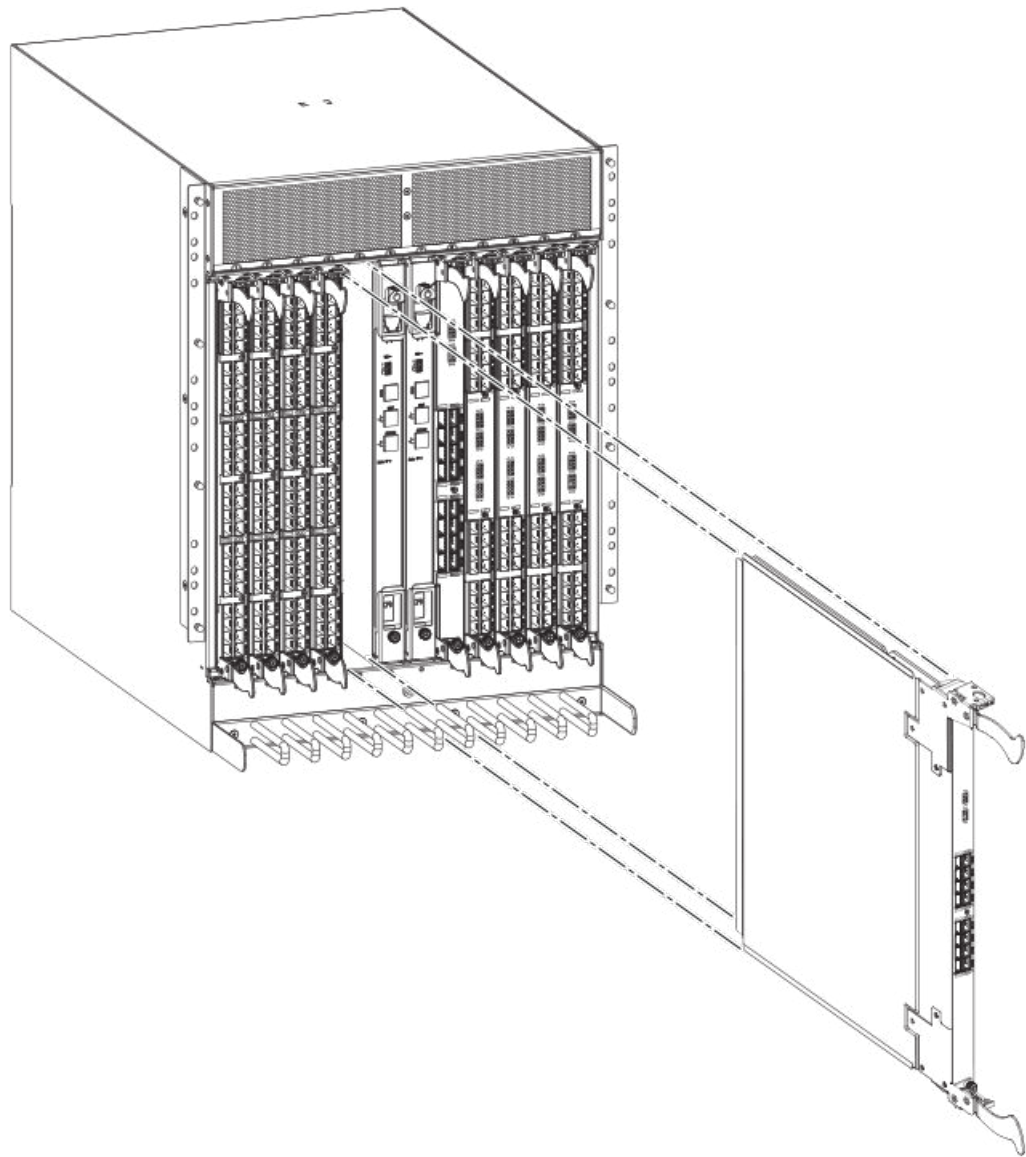

Replacing a core switch blade (CR16-8)

Follow electrostatic discharge (ESD) precautions when replacing a blade. Wear a wrist grounding strap connected to chassis ground (if the Brocade DCX 8510-8 is plugged in) or a bench ground.



DANGER

For safety reasons, the ESD wrist strap should contain a series 1 megaohm resistor.

NOTE

The CR16-8 blade is compatible only with the Brocade DCX 8510-8.

NOTE

The Brocade DCX 8510-8 continues to operate while a core switch blade is being replaced.

Complete the following steps to replace the core switch blade.

1. Open the ejectors by rotating them toward the center of the blade face. Orient the CR blade so that the handles are toward you.
2. Align the flat side of the blade inside the top and bottom rail guides in the slot with the components facing right, and slide the blade into the slot until it is firmly seated.
3. Close the ejectors by rotating them away from the center of the blade. The levering action of the ejectors seats the blade in the slot.
4. Power on the blade by screwing in the thumbscrews.
5. Verify that the power LED is green (might require a few seconds). If not, ensure that the core switch blade has power and is firmly seated and that the ejectors are in the locked position.
The status LED on the new blade is initially amber and will be until POST for the blade completes. This may take as long as several minutes. It then turns green.
6. Connect the cables to the new core switch blade. For the DCX 8510 models, if the QSFP cables are not used, make sure the rubber gaskets are in the QSFP transceivers.
7. Replace the chassis door.
8. Pack the faulty core switch blade in the packaging provided with the new core switch blade, and contact the Brocade DCX 8510-8 supplier to determine the return procedure.

Power supply removal and replacement

Use this procedure to remove and replace a power supply.

NOTE

Depending on the blade configuration of the chassis and the number of power supplies installed, the Brocade DCX 8510-8 may be able to continue operating during the replacement. Refer to "[Power specifications](#)" on page 122 to determine your power requirements. If there is insufficient power, the chassis will start powering down blades until the power demand can be met. Brocade DCX 8510-8 power supplies are 100-240 VAC, autosensing.

Time and items required

The replacement procedure for each power supply takes less than five minutes. A power supply unit or filler panel is required for the power supply replacement.

Identifying power supplies

The following figure shows the location and identification of the power supplies.

FIGURE 27 Power supply identification

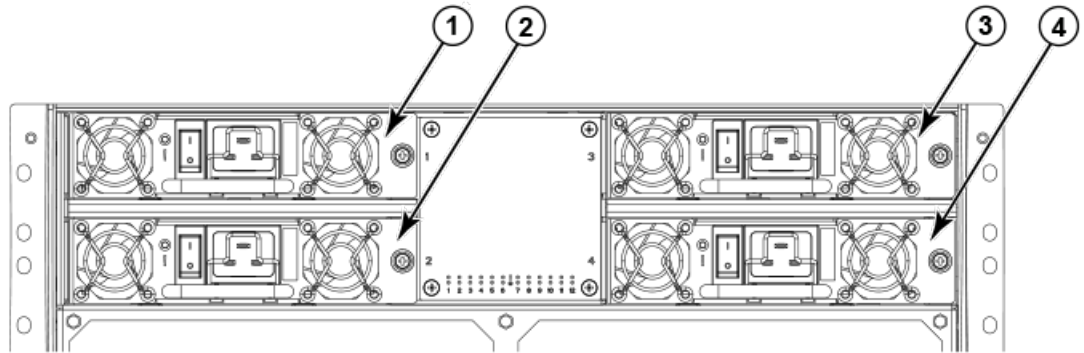

1. Power supply 1 (PS1)
2. Power supply 2 (PS2)
3. Power supply 3 (PS3)
4. Power supply 4 (PS4)

Removing a power supply

To remove a power supply, complete the following steps.

1. Perform the appropriate following action based on whether the Brocade DCX 8510-8 is operating:
 - If the Brocade DCX 8510-8 is not operating during the replacement procedure, go to step 2.
 - If the Brocade DCX 8510-8 is operating and will continue to operate during the replacement, check the power LEDs to verify that the minimum number of power supplies is functioning. Refer to [Providing power to the Brocade DCX 8510-8 Backbone](#) on page 27 to check your power requirements.
2. Turn off the power switch.
3. Unlatch the power cord retainer clip.
4. Remove the power cord.
5. Loosen the thumbscrew.
6. Grasp the handle and pull, sliding the power supply from the chassis and supporting the power supply from beneath as you remove it.

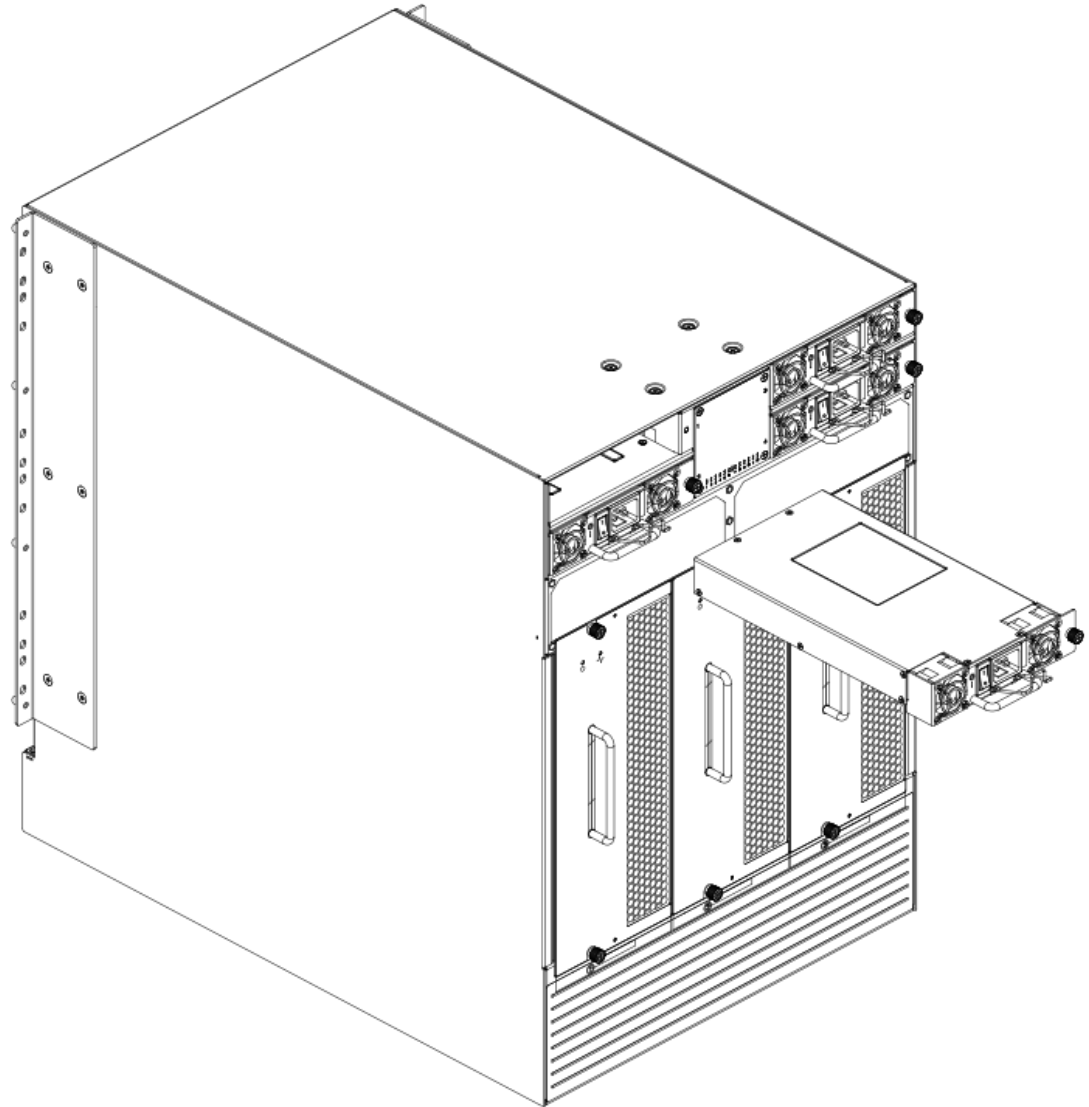
FIGURE 28 Removal and replacement of the power supply

Replacing a power supply

To replace a power supply, complete the following steps.

1. If you are not replacing the power supply, insert a filler panel into the slot.
2. Otherwise, insert the power supply into the slot. Verify that the power supply is seated by gently pulling on the handle.
3. Tighten the thumbscrew.
4. Replace the power cord.
5. Latch the power cord retainer clip.
6. Turn on the power switch.

7. Verify that the power LED on the power supply displays a steady green light.
8. If you are installing two new power supplies in a DCX or DCX 8510-8 chassis to bring the total of power supplies up to four, you should change the switchstatus policy settings for power supplies to the following in order to enable the call home feature if one power supply goes down:

```
switch.status.policy.PowerSupplies.down = 1
```

```
switch.status.policy.PowerSupplies.marginal = 0
```

For more details on executing the **switchStatusPolicyShow** and **switchStatusPolicySet** commands, refer to the *Fabric OS Command Reference*.

Blower assembly removal and replacement

Use this procedure to remove and replace a blower assembly.

NOTE

The Brocade DCX 8510-8 can continue operating during the replacement if the other two blower assemblies are operating. To ensure continuous adequate cooling, maintain three operating blower assemblies at all times except for the brief period when replacing a blower assembly.

Time and items required

The replacement procedure for each blower assembly takes less than 5 minutes. The following items are required for the blower assembly replacement:

- Replacement blower assembly
- #2 Phillips screwdriver

Removing a blower assembly

Complete the following steps to remove a blower assembly from the chassis.

1. Before removing a blower assembly, verify that the other blower assemblies are functioning correctly. The power LEDs should be steady green.
2. Use the screwdriver to loosen the captive screws at the top and bottom of the blower assembly.
3. Grasp the handle and pull, sliding the blower assembly from the chassis and supporting the blower assembly from beneath as you remove it.

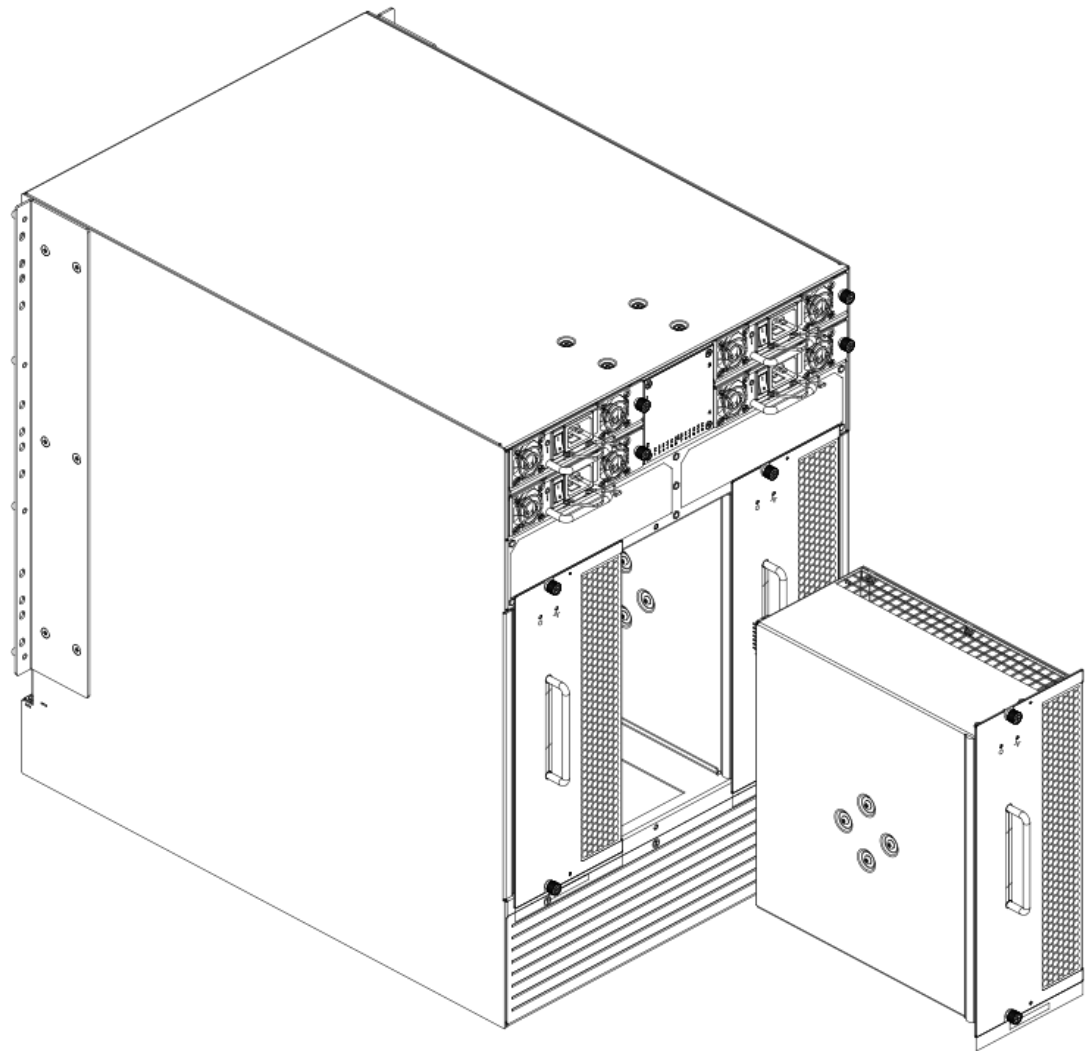
FIGURE 29 Removal and replacement of the blower assembly

Replacing a blower assembly

Complete the following steps to replace the blower assembly in a chassis.

1. Orient the blower assembly and slide it into the chassis, pushing firmly to ensure that it is seated.
2. Verify that the power LED displays a green light.
3. Use the screwdriver or your fingers to tighten the captive screws.

WWN card removal and replacement

There are two WWN cards located beneath the WWN bezel (logo plate). Use this procedure to remove and replace the WWN cards. If Brocade Support has determined that a WWN card needs to be

replaced, you need to power-down the chassis, and then both the WWN cards must be replaced as a matched pair.

Time and items required

Allow approximately 20 minutes to replace the WWN cards. The following items are needed to replace the WWN cards:

- Electrostatic discharge (ESD) grounding strap
- #2 Phillips screwdriver (required only for some versions of the WWN card)
- If a serial console session is used: serial cable and a workstation computer with a terminal emulator application (such as HyperTerminal for Windows systems or TIP for Solaris systems)

Verifying the need for replacement

Before replacing a WWN card, verify that the replacement is necessary. Any of the following events can indicate that the card requires replacement:

- Status LEDs on the WWN bezel not reflecting the actual status of the components.
- Power or Status LEDs on WWN card (beneath logo plate) indicate a problem.
- Problems viewing or modifying the data stored on the WWN card.
- Error messages regarding WWN units #1 or #2 from the **chassisshow** output.

Preparing for the WWN card replacement

If the WWN cards require replacement, complete the following steps. Follow electrostatic discharge (ESD) precautions.



DANGER

For safety reasons, the ESD wrist strap should contain a series 1 megaohm resistor.

1. Open a Telnet session to the chassis and log in to the active CP as admin. The default password is "password".
2. Verify that you are logged in to the active CP. Run the **haShow** command to determine the active CP.
3. Run the **supportSave** command on the active CP to capture all settings. These will be used later to verify the settings have been correctly programmed.
4. Contact Brocade Technical Support for replacement of both WWN cards. Brocade Support will request the partner or OEM to send two WWN cards from FRU inventory to the nearest Brocade Support office to be reprogrammed. Brocade Support will require the **Supportsave** data taken in the previous step so that the replacement cards can be reprogrammed prior to shipping to the partner or your site.

NOTE

Do not execute the **frureplace** command. The command will no longer be functional beginning with the release of Fabric OS 7.0.0c, but users with earlier versions of the Fabric OS should also *not* run the command.

Removing the WWN card and WWN bezel (logo plate)

When both the replacement WWN cards have been received, complete the following steps to remove the bezel and faulted WWN cards.

Follow electrostatic discharge (ESD) precautions. Wear a wrist grounding strap connected to chassis ground (if the chassis is plugged in) or a bench ground.



DANGER

For safety reasons, the ESD wrist strap should contain a series 1 megaohm resistor.

1. Open a Telnet session to the chassis and log in to the active CP as admin. The default password is "password".
2. Verify that you are logged in to the active CP. Run the **haShow** command to determine the active CP.
3. Run the **supportsave** command on the active CP to capture all settings. If any problem occurs during the replacement, the **supportsave** information will be important for solving the problem.
4. Run the following commands on the chassis before replacing the cards so that the data can be verified after the replacement:

1. **licenseidshow**
2. **ipaddrshow**
3. **switchname**
4. **chassisname**
5. **wwncardshow ipdata**
6. **chassisshow** (look at the WWN and Chassis information at the bottom)
7. **ficonshow switchrnid**

The factory serial number and the sequence number in the following outputs should match, except in the **ficonshow switchrnid**, which will have a number appended to the front indicating that the logical switch number, if virtual fabrics is enabled:

```
switch:FID128:root> chassisshow
<output truncated>
WWN Unit: 1
Header Version:          2
Power Consume Factor:   -1
Factory Part Num:       60-1000491-05
Factory Serial Num:     AFX2533G001
Manufacture:            Day: 19 Month: 1 Year: 2012
Update:                 Day: 5 Month: 5 Year: 2014
Time Alive:             756 days
Time Awake:             3 days
```

```
WWN Unit: 2
Header Version:          2
Power Consume Factor:   -1
Factory Part Num:       60-1000491-05
Factory Serial Num:     AJX0416G02H
Manufacture:            Day: 12 Month: 8 Year: 2011
Update:                 Day: 5 Month: 5 Year: 2014
Time Alive:             897 days
Time Awake:             3 days
```

Chassis Factory Serial Num: AFY2530G00S

```
switch:FID128:root> ficonshow switchrnid
{
  {Switch WWN          Flag Parm
   10:00:00:05:1e:95:b1:00 0x00 0x200a00
   Type number:         SLKWRM
   Model number:        DCX
   Manufacturer:        BRD
   Plant of Manufacture: CA
   Sequence Number:     0AFX2533G001
   tag:                 b6ff
```

}

5. Login to the chassis and execute the **switchcfgpersistentdisable** command on the main switch and other logical switches. The **switchcfgpersistentdisable** command disables the switches, and ensures they remain disabled after the power is cycled. This allows you to check all the settings so that you can verify the settings before placing the chassis back into production.

```
switch:FID128:root> switchcfgpersistentdisable
Switch's persistent state set to 'disabled'
switch:FID128:root>
```

If there are other logical switches on your chassis, use the **setcontext** command to connect to all the other switches and then run **switchcfgpersistentdisable** on these switches as well.

6. Power down the entire chassis.
7. Remove the screws from the WWN bezel on the back of the chassis. Pull the bezel away from the chassis and set it aside. The two WWN cards are now visible.
8. Use a Phillips screwdriver to unscrew the screws that secure each WWN card to the chassis. Label the WWN cards and cables with #1 for the left side and #2 for the right side, for future reference.
9. Disconnect the WWN cable by depressing the cable connector latch and pulling the connector from the WWN module.
10. Hold the WWN cards by the edges and gently pull them out from the chassis.
11. Set the WWN card on a static-free surface, such as a grounding pad.

FIGURE 30 Removal and replacement of the WWN bezel (logo plate) and WWN card

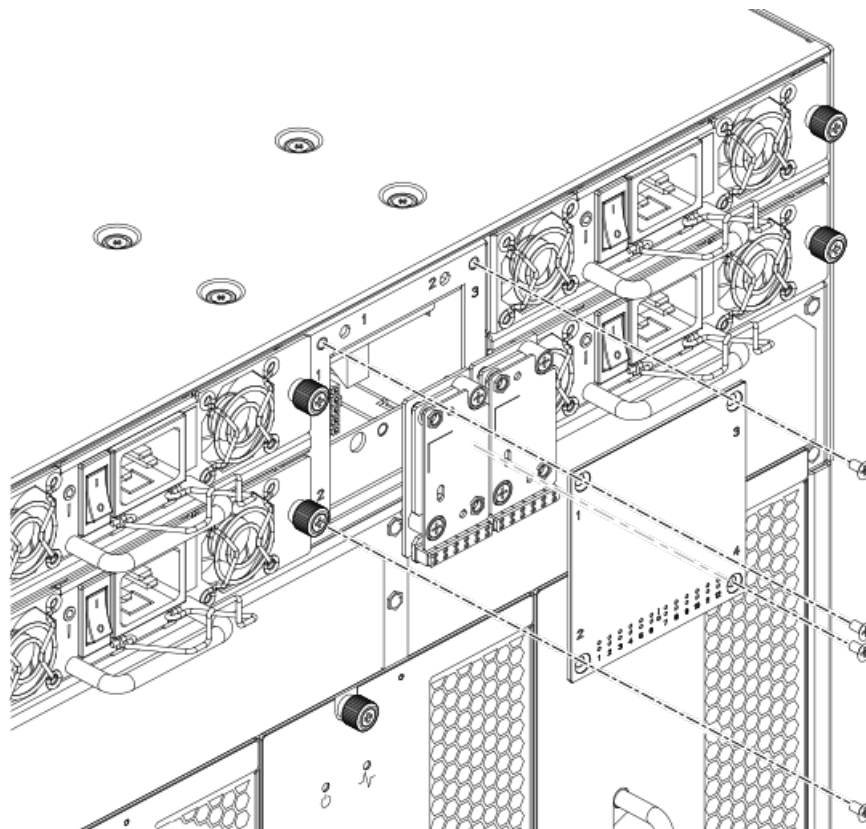

Replacing the WWN card and WWN bezel (logo plate)

Complete the following steps to replace the bezel and the WWN cards.

Follow electrostatic discharge (ESD) precautions. Wear a wrist grounding strap connected to chassis ground (if the Brocade DCX 8510-4 is plugged in) or a bench ground.



DANGER

For safety reasons, the ESD wrist strap should contain a series 1 megaohm resistor.

1. Ensure that the chassis is still powered off. If not, power down the entire chassis.
2. Unpack the two new WWN cards and save the packaging for the faulty WWN cards. The WWN cards and cables are labeled #1 for the left slot and #2 for the right slot.
3. Hold each card by the edges and insert the WWN cable onto the WWN module until the cables are fully seated.
4. Hold each card by the edges and slide the card into the chassis. Use the Phillips screwdriver and the screws to secure the WWN card to the chassis.
5. Power on the chassis and wait for five minutes for the chassis to boot.
6. Verify that the WWN card is correctly connected by checking the LEDs on the WWN card to see if they reflect the status of the components.

NOTE

The LEDs may take up to two minutes after WWN card installation to begin functioning.

7. Install the WWN bezel. Orient the bezel on the chassis. Insert and tighten the screws.
8. Verify the new card settings by running the following commands and comparing the output with the original **supportsave** data:
 1. **licenseidshow**
 2. **ipaddrshow**
 3. **switchname**
 4. **chassisname**
 5. **wwncardshow ipdata**
 6. **chassisshow** (look at the WWN and Chassis information at the bottom)
 7. **ficonshow switchrnid**
9. Run the **switchcfgpersistentenable** command to persistently enable each logical switch, that were disabled before removing the WWN cards:

```
switch:FID128:root> switchcfgpersistentenable
Switch's persistent state set to 'enabled'
```
10. Pack the faulty WWN cards in the packaging provided with the new cards, and return them to Brocade Support for failure analysis (FA).

Transceiver removal and replacement

Use the procedures in this section to remove and replace various types of transceivers supported.

| Blade | Transceiver | Auto-negotiate/Fixed | Speeds supported(xGbps) |
|---------------------|-------------|----------------------|-------------------------|
| FC8-32E and FC8-48E | SFP+ | Auto negotiate | 2, 4, and 8. |

| Blade | Transceiver | Auto-negotiate/Fixed | Speeds supported(xGbps) |
|---------------------|----------------------------|----------------------|--|
| FC8-64 | mSFP | Auto negotiate | 2, 4, and 8. |
| FC16-32 and FC16-48 | SFP+ | Auto negotiate | 2, 4, 8, and 16 |
| FC16-32 and FC16-48 | 10-Gbps SFP+ | Fixed | 10 |
| FCOE10-24 | 10-GbE SFP+ (only optical) | Fixed | 10 |
| FC16-64 | QSFP | Auto negotiate | 4, 8, and 16. However, all the four ports within a quad-SFP should be of the same speed. |
| CR16-4/8 | QSFP | Fixed | 16 |

Time Required

The replacement procedure for a transceiver takes less than five minutes.

Items Required

- Replacement mSFP, SFP, SFP+, or XFP
- Optical transceiver extraction tool (for SFP, SFP+, and XFP transceivers)

Most Brocade switches and backbones come with a transceiver extraction tool and holster. The extraction tool is designed to remove transceivers from switches and blades where the space is limited.

FIGURE 31 Optical transceiver (SFP+) extraction tool



Removing an SFP+ transceiver

Complete the following steps to remove an SFP+ transceiver.

1. Remove any cables that are inserted into the transceiver. Use the extraction tool to open the cable latching mechanism.
2. Using the hooked end of the tool, pull the bail (wire handle) away from its pivot point and out, sliding the transceiver out of the switch or blade.

The 16 Gbps SFP+ transceivers have an attached pull tab like the mSFPs. Instead of using the tool, simply grasp the pull tab and pull straight out to remove the 16 Gbps SFP+ from the switch or blade. Refer to the illustration for the mSFP transceiver for the basic appearance of the 16 Gbps transceiver.

FIGURE 32 Replacing an optical transceiver

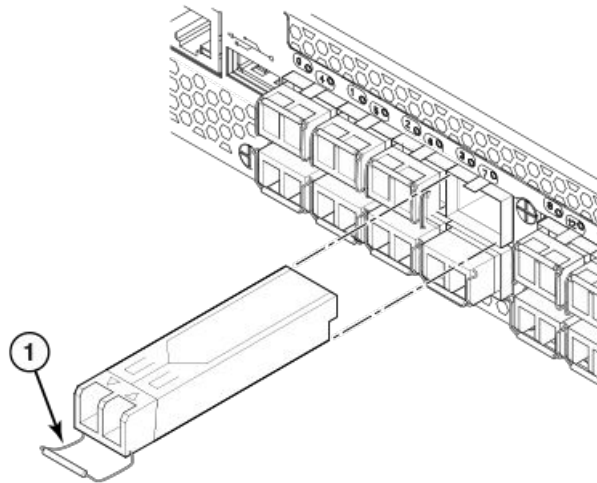

1. SFP/XFP bail

FIGURE 33 Replacing a 16 Gbps SFP+ optical transceiver

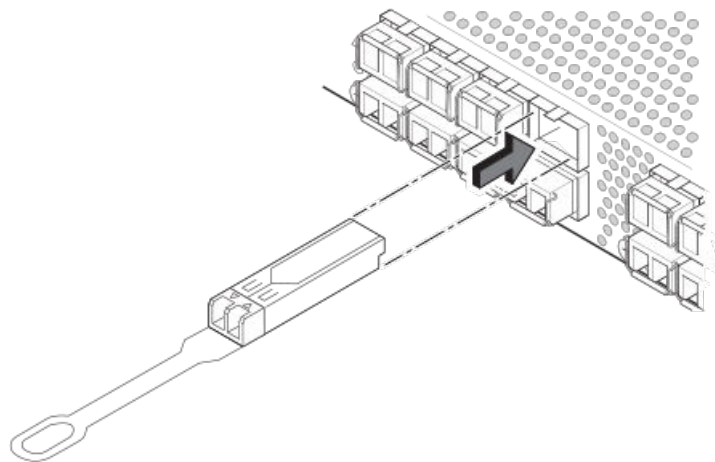

Replacing an SFP+ transceiver

Complete the following steps to replace an SFP+ transceiver.

1. Making sure that the bail (wire handle) is in the unlocked position, position the optical transceiver so that the key is oriented correctly to the port. Insert the transceiver into the port until it is firmly seated and the latching mechanism clicks; then close the bail.

The 16 Gbps SFP+ transceivers do not have bails. Use the tab on the 16 Gbps SFP+ transceivers to help gently push the transceiver into the port. Do not push so hard as to bend the tab.

Transceivers are keyed so that they can only be inserted with the correct orientation. If a transceiver does not slide in easily, ensure that it is correctly oriented.

2. Position a cable so that the key (the ridge on one side of the cable connector) is aligned with the slot in the transceiver. Insert the cable into the transceiver until the latching mechanism clicks.

Cables are keyed so that they can be inserted in only one way. If a cable does not slide in easily, ensure that it is correctly oriented. Do not insert a cable intended for an mSFP transceiver into a regular SFP+ transceiver. You may damage the cable. Do not force a standard SFP cable into an mSFP transceiver. You may damage the transceiver.

Removing and replacing an mSFP optical transceiver

Use this procedure to remove and replace mSFP transceivers and follow these guidelines while removing and replacing mSFP transceivers.

- Do not use the SFP+ extraction tool to remove the mSFP transceivers.
- The mSFP transceivers are used only with the FC8-64 port blade. Narrower OM-3 LC cables are used to connect the FC8-64.
- It is recommended that the optical cable should be either removed from or inserted into the mSFP while the transceiver is out of the blade due to the port density.
- mSFP optical transceivers should not be inserted into ports intended for SFP+ transceivers. They will be faulted on power-up for Fabric OS 7.0.0 and later.
- Cables for mSFP transceivers should not be used with standard SFP+ transceivers.
- The pull tabs are not designed to be bent. Doing so may result in damage to the pull tab.

Removing an mSFP transceiver

Complete the following steps to remove an mSFP transceiver.

1. Grasp the pull tab firmly and pull the unit out of the port.
2. Remove the cable from the transceiver.

FIGURE 34 Optical mSFP transceiver

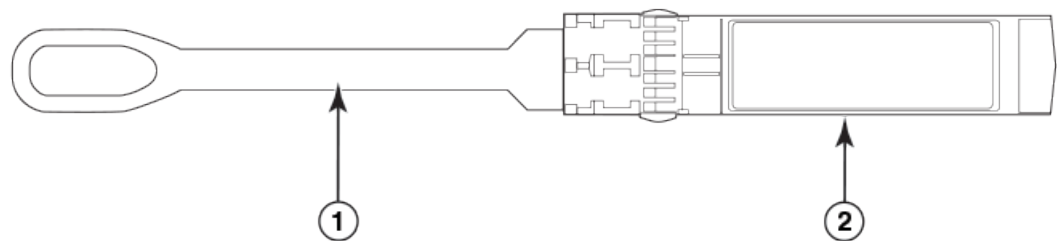

1. Pull tab
2. mSFP transceiver

Replacing an mSFP transceiver

Complete the following steps to replace an mSFP transceiver.

1. Insert the cable into the new transceiver until the latching mechanism clicks.
2. Position the optical transceiver so that the key is oriented correctly to the port. Insert the transceiver into the port until it is firmly seated and the latching mechanism clicks.

Transceivers are keyed so that they can only be inserted with the correct orientation. If a transceiver does not slide in easily, ensure that it is correctly oriented.

Removing and replacing a QSFP optical transceiver

Use this procedure to remove and replace QSFP transceivers supported on the FC16-64 port blades and core switch blades. Do not use the extraction tool to remove the QSFP transceivers. Follow these guidelines while removing and replacing QSFP transceivers:

- The QSFP transceivers are used only with the FC16-64 port blades and core switch blades. However, the part numbers of QSFP transceivers supported on FC16-64 port blade and the core blades are not the same and are not interchangeable.

TABLE 12 Qualified transceivers for FC16-64 port blade and the core blades

| Brocade part number | Part type | Cable length | Port speeds | Supported blades |
|---------------------|------------------|--------------|-------------------------------------|------------------|
| 57-1000294-01 | QSFP transceiver | 100 m OM4 | Auto-negotiable 4-, 8-, and 16-Gbps | FC16-64 |
| 57-1000267-01 | QSFP transceiver | 100 m OM4 | Only fixed 16-Gbps | CR16-4/8 |
| 57-0000090-01 | QSFP transceiver | 50 m OM3 | | |

- It is recommended that the optical cable should be either removed from or inserted into the QSFP while the transceiver is out of the blade due to the port density.
- QSFP optical transceivers should not be inserted into ports intended for SFP+ or mSFP transceivers. They will be faulted on power-up.
- Cables for QSFP transceivers should not be used with standard SFP+ or mSFP transceivers.
- The pull tabs are not designed to be bent. Doing so may result in damage to the pull tab.

Removing a QSFP transceiver

Complete the following steps to remove a QSFP cable.

1. Grasp the rubber housing on the end of the cable and pull it straight out of the QSFP transceiver.
2. If the QSFP transceiver also needs to be replaced, remove the QSFP transceiver by rotating the bail down and using the bail to pull the transceiver out of the connector on the blade.
3. Repeat for each cable that requires replacement.

FIGURE 35 QSFP transceiver (bail open)

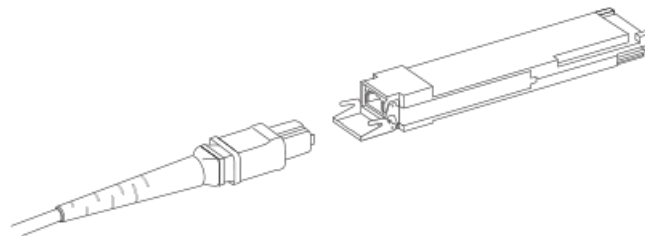

1. QSFP transceiver
2. Bail

Replacing a QSFP transceiver

Complete the following steps to replace a QSFP transceiver.

1. If the QSFP transceiver is being replaced, grasp the bail of the new QSFP and push the QSFP into the connector on the blade until it is firmly seated. The QSFP is keyed to fit into the connector in one way. The status LED initially blinks amber after installation, then displays steady amber.
2. Grasp the QSFP cable by the rubber housing and push it into the QSFP transceiver until it is firmly seated. The cable housing is keyed to fit into the QSFP in one way.

The status LED displays steady amber until both ends of the cable are inserted and the link is established. When the link is fully established, the LED displays steady green.

3. Repeat for each cable that requires replacement.

Once all the cables are attached, refer to the *Fabric OS Administrator's Guide* for the configuration procedure.

Qualified transceivers for the FC16-64 port blade and the core blades

The following table shows the qualified transceivers for the FC16-64 port blade and the core blades.

TABLE 13 Qualified transceivers for FC16-64 port blade and the core blades

| Brocade part number | Part type | Cable length | Port speeds | Supported blades |
|---------------------|------------------|--------------|-------------------------------------|------------------|
| 57-1000294-01 | QSFP transceiver | 100 m OM4 | Auto-negotiable 4-, 8-, and 16-Gbps | FC16-64 |
| 57-1000267-01 | QSFP transceiver | 100 m OM4 | Only fixed 16-Gbps | CR16-4/8 |
| 57-0000090-01 | QSFP transceiver | 50 m OM3 | | |

NOTE

The QSFP transceivers supported on FC16-64 port blade are not interchangeable with QSFP transceivers supported on the core blades.

Inter-chassis link (ICL) cable removal and replacement

Use this procedure to remove and replace an ICL QSFP cable.

NOTE

The QSFP ports can be used only with an inter-chassis link (ICL) license. After the addition or removal of a license, the license enforcement is performed on the ports only when the **portdisable** and **portenable** commands are issued on the ports. An ICL license must be installed on all Brocade Backbones forming the ICL connection. Beginning with Fabric OS v7.0.1, up to nine neighboring Brocade DCX 8510 series chassis can be connected with the QSFP cables. Under Fabric OS v7.0.0, six chassis can be connected.

NOTE

For the Brocade DCX 8510 Backbones, an off-the-shelf QSFP cable up to 50 meters long can be used as an ICL cable.

NOTE

For the Brocade DCX 8510 Backbones, if the QSFP cables are not used, make sure the rubber gaskets are in the QSFP transceivers.

The following table describes the connector port LED patterns and the recommended actions for those patterns.

TABLE 14 ICL QSFP connector port LEDs

| LED purpose | Color | Status | Recommended action |
|-----------------------|-----------------------|--|---|
| QSFP connector status | No light (LED is off) | No QSFP module, all four QSFP ports are disabled. | No action required if QSFP not present or verify that the QSFP is fully inserted. |
| | Steady amber | QSFP module is in, all four ports have no signal/no sync. | No action required if QSFP only is installed or ensure that the cable is properly connected. If the LED remains amber, consult the Brocade DCX 8510-8 supplier. |
| | Blinking amber | Port is disabled or faulted, FC link activity, segmented, loopback mode, also during transition between QSFP cable insertion and confirmation. | Check for console messages or wait for all four ports to come online. |
| | Steady green | Both ends of QSFP cable are in and all ports are online. Full link is established. | No action required. |

Follow this procedure to install the QSFP cables. Refer to the *Fabric OS Administrator's Guide* for the configuration procedure and requirements.

The following figure shows a QSFP cable and transceiver. The QSFP connectors on the core blades are labeled by trunk group (trunking is optional) for ease of installation. The subsequent figures show acceptable cabling configurations for the ICL feature. The recommended topology is the parallel type where there are four QSFP cables connected between any pair of Brocade DCX 8510 series chassis. The full mesh configuration is also supported.

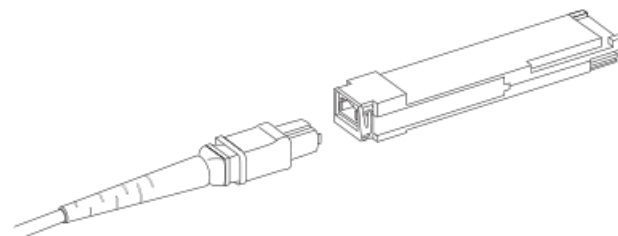
FIGURE 36 QSFP cable and transceiver

Time and items required

The replacement procedure for an ICL cable takes less than five minutes. Only a replacement ICL cable is required for this procedure.

Removing an ICL cable

Complete the following steps to remove a QSFP cable.

1. Grasp the rubber housing on the end of the cable and pull it straight out of the QSFP transceiver.
2. If the QSFP transceiver also needs to be replaced, remove the QSFP transceiver by rotating the bail down and using the bail to pull the transceiver out of the connector on the blade.
3. Repeat for each cable that requires replacement.

FIGURE 37 QSFP transceiver (bail open)

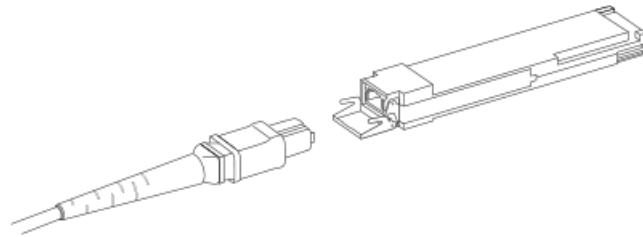

1. QSFP transceiver
2. Bail

Replacing an ICL cable

Complete the following steps to replace a QSFP cable.

1. If the QSFP transceiver is being replaced, grasp the bail of the new QSFP and push the QSFP into the connector on the blade until it is firmly seated. The QSFP is keyed to fit into the connector in one way. The status LED initially blinks amber after installation, then displays steady amber.
2. Grasp the QSFP cable by the rubber housing and push it into the QSFP transceiver until it is firmly seated. The cable housing is keyed to fit into the QSFP in one way.

The status LED displays steady amber until both ends of the cable are inserted and the link is established. When the link is fully established, the LED displays steady green.

3. Repeat for each cable that requires replacement.

Once all the cables are attached, refer to the *Fabric OS Administrator's Guide* for the configuration procedure.

Possible ICL configurations

The following figure illustrates one possible QSFP cable configuration between two DCX 8510 series chassis. Each of two cores in one chassis should be interconnected with each of two cores in the second chassis. This provides for inter-chassis link (ICL) trunking between chassis, ensuring redundancy. Parallel connections between core blades are recommended.

FIGURE 38 QSFP cable connections for Brocade DCX 8510 chassis (sample configuration)

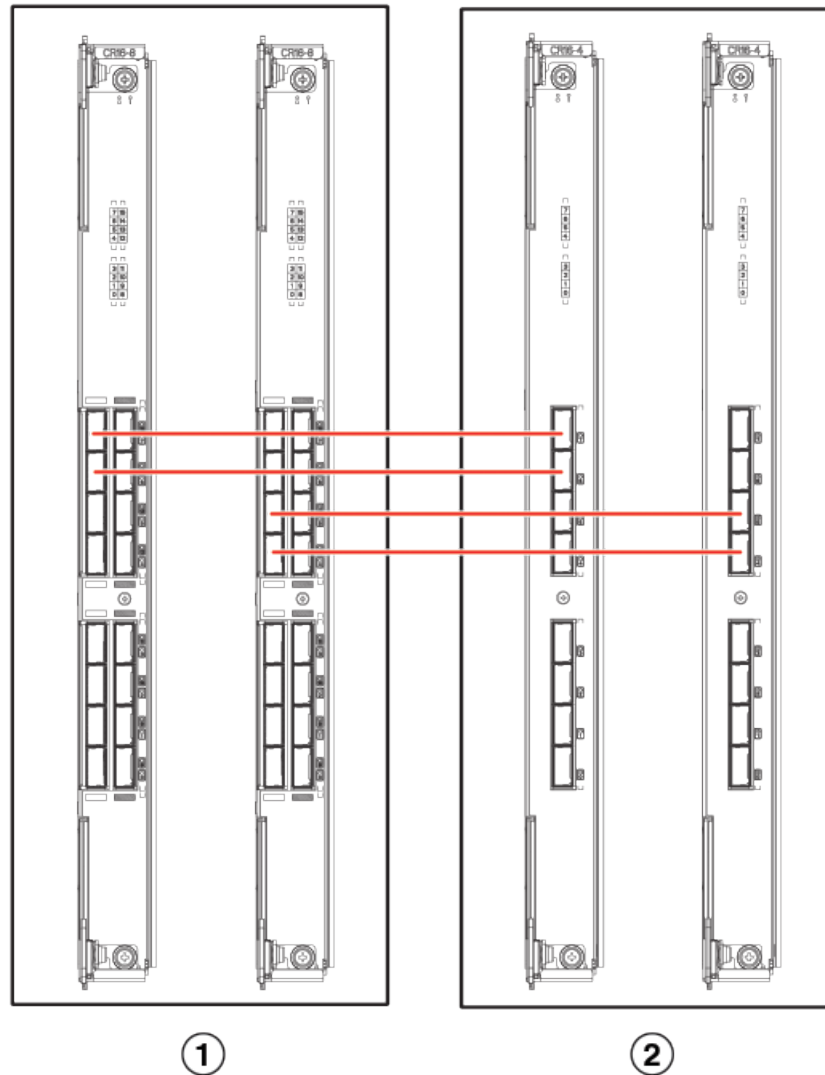

1. Chassis 1 - DCX 8510-8
2. Chassis 2 - DCX 8510-4

The DCX 8510 chassis can be connected in a core/edge configuration. The following figure shows two core and four edge chassis. Although DCX 8510-8 chassis are shown in the figure, the chassis can be either DCX 8510-4 or DCX 8510-8. The cabling scheme should follow the parallel example shown in the previous figure. Each line in the example actually represents four cables running between the chassis.

FIGURE 39 DCX 8510 core/edge ICL topology

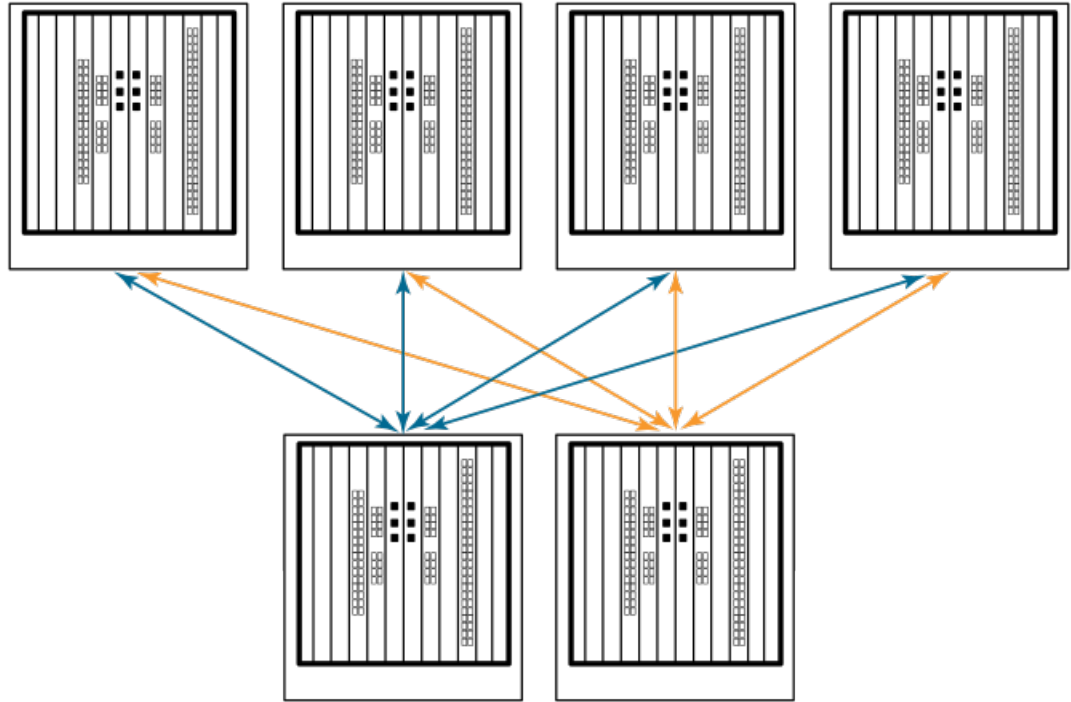

The DCX 8510 chassis can also be connected in a full mesh configuration as shown in the following figure. Although DCX 8510-8 chassis are shown in the figure, the chassis can be either DCX 8510-4 or DCX 8510-8. In this example, the trunk groups are shown in color.

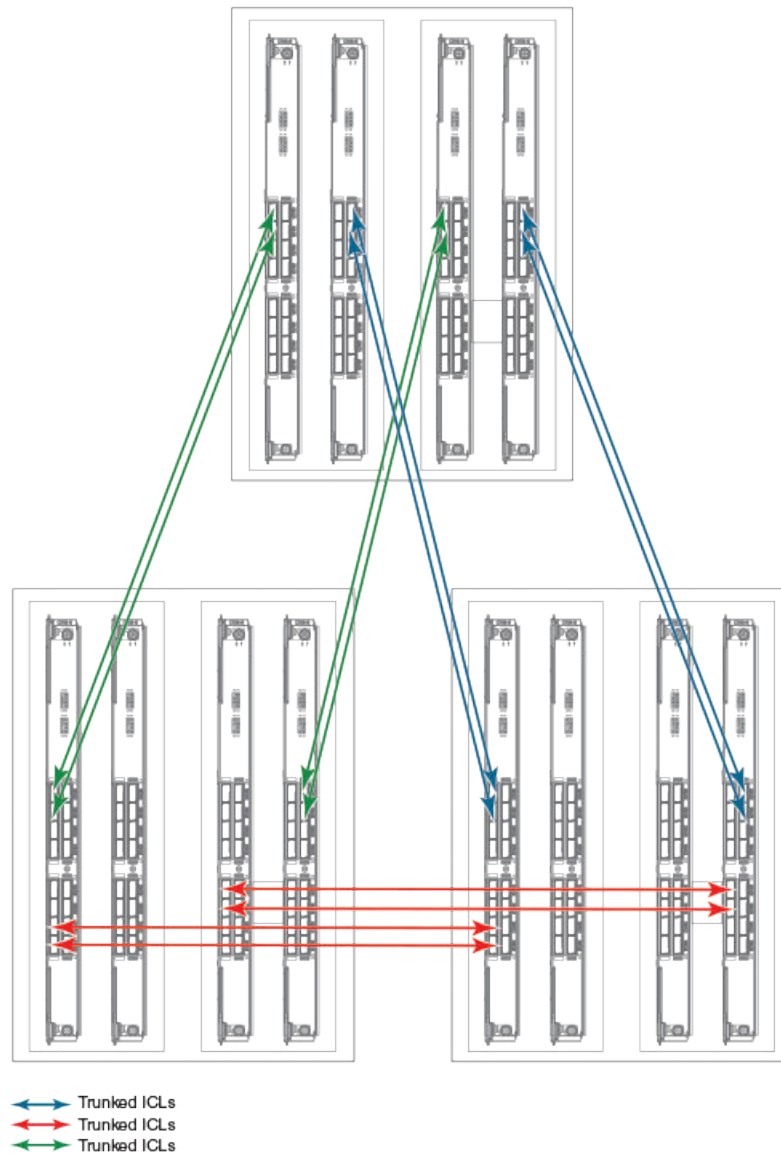
FIGURE 40 DCX 8510 full mesh ICL topology

Brocade DCX 8510-8 chassis removal and replacement

This section describes how to remove and replace the Brocade DCX 8510-8 chassis (with its backplane). The basic steps are:

1. [Faulty Brocade DCX 8510-8 chassis indicators](#) on page 114
2. [Recording critical Brocade DCX 8510-8 and SAN information](#) on page 115
3. [Disconnecting from network and fabric](#) on page 117
4. [Removing components from the chassis](#) on page 118
5. [Installing the replacement chassis](#) on page 118

6. [Installing components into the new chassis](#) on page 119
7. [Downloading the configuration](#) on page 120
8. [Verifying correct operation of system](#) on page 120
9. [Reconnecting the system to the network and fabric](#) on page 122
10. [Verifying correct configuration of the fabric](#) on page 122

NOTE

The Brocade DCX 8510-8 must be removed from the fabric and powered off to perform this procedure. Contact your support provider if you have any questions about whether the chassis requires replacement.

Time and items required

The chassis replacement takes approximately 3 hours.

The following items are required for the chassis replacement:

- Electrostatic discharge (ESD) grounding strap
- ESD grounding pads for protecting all blades and WWN cards
- Serial cable and workstation computer with a terminal emulator application (such as HyperTerminal for Windows systems or TIP for Solaris systems), required only if serial console session used
- Pallet jack or hydraulic or assisted lift that raises a minimum of 140 cm (55 in.) and carries a minimum of 113 kg (250 lb)
- A surface on which to place the old chassis, such as a second lift or the pallet originally provided with the old chassis
- #2 Phillips screwdriver

Faulty Brocade DCX 8510-8 chassis indicators

Verify that replacement of the chassis is necessary. Ensure that the components are firmly seated when troubleshooting, and contact your support provider with any questions about whether the chassis should be replaced.

Any of the following events might indicate the need to replace the chassis:

- Visible mechanical damage to the chassis, including damage to sheet metal or card guides that prevents correct installation of a blade.
- Bent or damaged connectors on the backplane (the surface inside the chassis to which the blades connect).
- One or more components (such as a power supply, blower assembly, port blade, control processor blade, core switch blade, or WWN card) do not function properly even after the component was replaced.
- Intermittent FAULTY codes for blades. Reseat the blade and visually inspect the top ejector stiffening rail for possible wear or damage. It is important that the blade ejector handles not slip out during blade installation. If this happens, it is usually due to excessive wear or damage to the top ejector stiffening rail.
- The **psShow** or **fanShow** commands continue to show a faulty component even though the component was replaced.
- The **slotShow** command continues to show a faulty control processor, core switch, or port blade even though the blade was replaced.

Recording critical Brocade DCX 8510-8 and SAN information

All commands must be entered from a CLI session (Telnet or serial) to the active CP blade unless otherwise indicated.

Run **supportShow**, which includes most of the information in the following table and more. The customer should record the location of the .txt files, which are created by the customer in this procedure and are not called out in the **supportShow** results.

For detailed information about Fabric OS commands, refer to the *Fabric OS Command Reference*. Use a checklist to ensure that all required information is recorded.

TABLE 15 Critical information checklist

| Checked? | Data | Notes |
|--|---|-------|
| Configuration information | | |
| | Location of "config-switch.txt" file | |
| | Location of "config-miscinfo.txt" file | |
| | IP address, subnet mask | |
| | WWN for Brocade DCX 8510-8 | |
| SAN profile | | |
| | Location of "SANbefor.txt" file | |
| | Notes regarding nsshow output | |
| | Notes regarding nsallshow output | |
| | Notes regarding switchshow output | |
| | Notes regarding fabricshow output | |
| Output from supportshow command | | |
| | Location of "spptshow.txt" file | |
| | Notes regarding supportshow output | |
| Information about the new chassis | | |
| | New factory serial number | |
| | New serial number (if available) | |

1. Open a Telnet session and log in to the Brocade DCX 8510-8 as **admin**. The default password is *password*. Enable the logging function on your Telnet or serial console connection.
2. Back up the current configuration.

NOTE

If you are using the Virtual Fabric feature, you should run **configupload -vf** before running the **configupload** command to save the logical switch configuration.

- Enter **configUpload -all**; then enter the requested information at the prompts.

This command uploads the Brocade DCX 8510-8 configuration to the customer-defined FTP server, making it available for downloading. For more information about this command, refer to the *Fabric OS Command Reference*.

```
switch:admin> configupload
Protocol (scp or ftp) [ftp]: ftp
Server Name or IP Address [host]: 123.123.123.123
User Name [user]: Admin24
File Name [config.txt]: config-switch0.txt
Password:
Upload complete
switch:admin>
```

- Alternatively, you can save the configuration file to a Brocade USB device.

3. Record the WWN value: Enter **wwn**; then copy the command output into a file named config-miscinfo.txt.

```
switch:admin> wwn
10:00:00:60:69:00:00:0a
```

4. Record the IP address information.

Enter **ipAddrShow -sw**; then copy the command output into the config-miscinfo.txt file.

```
switch:admin> ipaddrshow -sw
SWITCH
Ethernet IP Address: 10.32.50.12
Ethernet Subnetmask: 255.55.0.0
Fibre Channel IP Address: 1.2.3.4
Fibre Channel Subnetmask: 255.255.255.0
CP0
Ethernet IP Address: 10.32.50.10
Ethernet Subnetmask: 255.55.0.0
HostName : cp0
Gateway Address: 10.32.40.1
CP1
Ethernet IP Address: 10.32.50.11
Ethernet Subnetmask: 255.55.0.0
HostName : cp1
Gateway Address: 10.32.40.1
Backplane IP address of CP0 : 10.0.0.6
Backplane IP address of CP1 : 10.0.0.7
switch:admin>switch:admin>
```

5. Display and record the manufacturer serial numbers.

Enter **chassisShow**; then copy the command output into the config-miscinfo.txt file.

"Factory Serial Num" and "Serial Num" are listed under "Chassis/WWN Unit 1." If the current WWN cards are the original cards, the factory serial number listed is the same as the chassis serial number.

```
switch:admin> chassisshow
Chassis Backplane Revision: 1F
SW BLADE Slot: 1
Header Version: 2
Power Consume Factor: -50
Factory Part Num: 60-0001532-03
Factory Serial Num: KP000000195
Manufacture: Day: 1 Month: 1 Year: 2007
Update: Day: 14 Month: 3 Year: 2012
Time Alive: 187 days
Time Awake: 3 days
<output truncated>
CHASSIS/WWN Unit: 1 (in same assembly as WWN Unit: 2)
Header Version: 2
```

```

Power Consume Factor:  -3
Factory Part Num:      60-0001501-07
Factory Serial Num:   FT02X805BE2
Manufacture:          Day: 26 Month: 3 Year: 2007
Update:              Day: 14 Month: 3 Year: 2009
Time Alive:          207 days
Time Awake:          3 days
<output truncated>
switch:admin>

```

6. Create a SAN "profile" by entering and recording the information provided by the following commands:

- **nsShow**
- **nsAllShow**
- **switchShow -qsf**
- **fabricShow**

Copy the command output into a text file named "SANbefor.txt." After the Brocade DCX 8510-8 is restored to the fabric, this information can be used to verify that no unintentional changes have occurred to the fabric.

```

switch:admin> nsshow
Enter Pid COS PortName NodeName TTL
<output truncated>
switch:admin> nsallshow
    12 Nx Ports in the Fabric
<output truncated>
switch:admin> switchshow
switchName: switch
<output truncated>
switch:admin> fabricshow
Switch ID Worldwide Name Enet IP Addr FC IP Addr Name
<output truncated>
switch:admin>

```

7. Enter **supportShow**; then copy the command output into a text file named "spptshow.txt."

NOTE

The **supportShow** command has a very long output and time for completion. It may last 20 minutes or longer depending on the size of the SAN.

This file provides a backup of all the information that might be required by Technical Support. The information can be used after the Brocade DCX 8510-8 is restored to the fabric to verify that no unintentional changes have occurred to the fabric.

```

switch:admin> supportshow
version: 7.0.0
<output truncated>
switch:admin>

```

8. Record the cable connections between the Brocade DCX 8510-8 and the target device and ports.
9. Run **supportSave** on the active CP. The information recorded can be very important in case you have difficulties during the replacement process.

Disconnecting from network and fabric

Complete the following steps to disconnect the chassis from the network.

1. Shut down the Brocade DCX 8510-8 using the **sysShutdown** command on the active CP.

```

switch:admin> sysshutdown
This command will shutdown the operating systems on your switch.
You are required to power-cycle the switch in order to restore operation.
Are you sure you want to shutdown the switch [y/n]?y
HA is disabled

```

```
Stopping blade 1
Shutting down the blade....
Stopping blade 2
Shutting down the blade....
Stopping blade 8
Shutting down the blade....
Broadcast message from root (pts/1) Tue Jul 18 14:23:06 2008...
The system is going down for system halt NOW !!
```



DANGER

Disconnect the power cord from all power sources to completely remove power from the device.

2. Power off the chassis by flipping all AC power switches to the off position. (The power supply status LED should turn off.)
3. Remove the power cords from the power supplies and the power outlets.
4. Remove the chassis door.
5. Label the cables connected to all blades and record the connections.
6. Disconnect the cables from the SFP+ transceivers in the application and port blades and set them aside. If you have mSFP transceivers in FC8-64 port blades, or QSFP transceivers in FC16-64 port blades, remove the transceivers and cables together and set them aside. The SFP+ transceivers can be left in the port blades or removed.
7. Disconnect all cables from the control processor and core switch blades.
8. Disconnect any ICL or QSFP cables.

Removing components from the chassis

Follow electrostatic discharge (ESD) precautions. Wear a wrist grounding strap connected to chassis ground (if the Brocade DCX 8510-8 is plugged in) or a bench ground.



DANGER

For safety reasons, the ESD wrist strap should contain a series 1 megaohm resistor.

1. Remove the chassis door ([Chassis door removal and replacement](#) on page 76) if not already done.
2. Remove the cable management comb ([Cable management comb removal and replacement](#) on page 77).
3. Remove the port blades or filler panels ([Port, application, and encryption blade removal and replacement](#) on page 78 and [Blade filler panel removal and replacement](#) on page 82).
4. Remove the core switch blades (CR16-8) ([Core switch blade \(CR16-8\) removal and replacement](#) on page 92).
5. Remove the control processor blades (CP8) ([Control processor blade \(CP8\) removal and replacement](#) on page 84).
6. Remove the power supplies or filler panels ([Power supply removal and replacement](#) on page 95).
7. Remove the blower assemblies ([Blower assembly removal and replacement](#) on page 98).
8. Remove the WWN bezel (logo plate) and WWN cards ([WWN card removal and replacement](#) on page 99).

Installing the replacement chassis

Complete the following steps to install the replacement chassis.

**DANGER**

Use safe lifting practices when moving the product.

**DANGER**

A completely empty Brocade DCX 8510-8 chassis weighs approximately 37.3 kg (82.2 lb) and requires a hydraulic or assisted lift to install it.

**DANGER**

Make sure the rack or cabinet housing the device is adequately secured to prevent it from becoming unstable or falling over.

1. If the chassis is in a cabinet, remove it from the cabinet.
2. Place the chassis on a lift or on the shipping pallet provided with the original chassis.
3. Unpack the new chassis:
 - a) Cut the bands that encircle the packaging.
 - b) Remove the lid and the kits and foam from the top of the chassis.
 - c) Lift the cardboard box off the chassis and remove the plastic bag from around the chassis. Save the packing materials for use when returning the old chassis.
 - d) Leave the chassis on top of the plastic shipping tray if the chassis must be transported to the installation location.

NOTE

The Brocade DCX 8510-8 packaging does not incorporate a wood pallet and pallet brackets. The chassis sits on top of a plastic shipping tray.

4. Use a pallet jack or other assisted lift to transport the new chassis to the installation area. Doorways must be wider than 91 cm (36 in.) to accommodate the chassis on the pallet.
5. Use a lift to raise the chassis to the correct level. If installing the chassis in a cabinet, follow the instructions provided by the rack kit manufacturer.

Installing components into the new chassis

Follow electrostatic discharge (ESD) precautions when installing new components. Wear a wrist grounding strap connected to chassis ground (if the Brocade DCX 8510-8 is plugged in) or a bench ground.

**DANGER**

For safety reasons, the ESD wrist strap should contain a series 1 megaohm resistor.

1. Replace the WWN bezel (logo plate) and WWN cards ([WWN card removal and replacement](#) on page 99).
2. Replace the blower assemblies ([Blower assembly removal and replacement](#) on page 98).
3. Replace the power supplies or filler panels ([Power supply removal and replacement](#) on page 95).
4. Replace the control processor blades (CP8) ([Control processor blade \(CP8\) removal and replacement](#) on page 84).
5. Replace the core switch blades (CR16-8) ([Core switch blade \(CR16-8\) removal and replacement](#) on page 92).

6. Replace the port blades or filler panels ([Port, application, and encryption blade removal and replacement](#) on page 78 and [Blade filler panel removal and replacement](#) on page 82).
7. Replace the cable management comb ([Cable management comb removal and replacement](#) on page 77).
8. Connect the power cords to the power supplies and the power outlets.
9. Replace the chassis door ([Chassis door removal and replacement](#) on page 76).
10. Power on the Brocade DCX 8510-8 ([Installing components into the new chassis](#)).

The Brocade DCX 8510-8 performs a power-on self-test (POST). The POST takes a minimum of three minutes and is complete when LED activity returns to the standard state.

11. Verify that the Brocade DCX 8510-8 is powered on and POST is complete (all power LED indicators on the blades should be a steady green).
12. Verify that all components are functioning correctly by checking their LEDs. If the LEDs do not indicate correct operation, try reinstalling the corresponding component.

Downloading the configuration

Once the chassis and its various components have been reassembled and powered back on, use the **configDownload** command to restore the original configuration. The **configDownload** command can be entered through a Telnet or serial session, but the Brocade DCX 8510-8 must have an Ethernet connection to the server name or IP address of the host for the download process to complete. For more information, refer to the **help configdownload** command or the *Fabric OS Command Reference*.

Complete the following steps to download the configuration.

1. Log in to the Brocade DCX 8510-8 as **admin**.

```
switch:admin> login
login: admin
password: xxxxxxxx
switch:admin>
```

NOTE

If you are using the Virtual Fabric feature, you must run **configdownload -vfbefore** running the **configdownload** command to restore the logical switch configuration.

2. Enter the **chassisDisable** command.
3. Enter the **configDownload** command.

```
switch:admin> configdownload -all
Server Name or IP Address [host]: 123.123.123.123
User Name [None]: Admin24
File Name [config.txt]: config-switch.txt
Password: xxxxxxxx
download complete
switch:admin>
```

4. Reboot the Brocade DCX 8510-8.

Verifying correct operation of system

Complete the following steps to verify the correct operation of the Brocade DCX 8510-8.

1. Log in to the Brocade DCX 8510-8 as **admin**.

```
switch:admin> login
login: admin
```



```
password: xxxxxxxx
switch:admin>
```

2. Enter the **slotShow -m** command and verify that all the installed cards are detected and that their status is operational (enabled).

```
switch:admin> slotShow -m
Slot   Blade Type   ID   Model Name   Status
-----
  1     SW BLADE     97   FC16-32     ENABLED
  2     SW BLADE     77   FC8-64      ENABLED
  3     SW BLADE     97   FC16-32     ENABLED
  4     SW BLADE     97   FC16-32     ENABLED
  5     CORE BLADE   99   CR16-4      ENABLED
  6     CP BLADE     50   CP8         ENABLED
  7     CP BLADE     50   CP8         ENABLED
  8     CORE BLADE   99   CR16-4      ENABLED
  9     SW BLADE     96   FC16-48     ENABLED
 10     SW BLADE     77   FC8-64      ENABLED
 11     SW BLADE     96   FC16-48     ENABLED
 12     SW BLADE     77   FC8-64      ENABLED
switch:admin>
```

3. Verify that the Brocade DCX 8510-8 is functioning correctly by entering **switchShow** or **switchStatusShow**.

This **switchShow** command displays the Brocade DCX 8510-8 and port status information.

```
switch:FID128:admin> switchshow
switchName: DCX8510_8
switchType: 120.1
switchState: Online
switchMode: Native
switchRole: Subordinate
switchDomain: 80
switchId: fffc50
switchWwn: 10:00:00:05:1e:39:e4:5a
zoning: ON (ZONE_CONFIG_NAME)
switchBeacon: OFF
FC Router: OFF
Allow XISL Use: OFF
LS Attributes: [FID: 128, Base Switch: No, Default Switch: Yes, Address Mode 0]
Index Slot Port Address Media Speed State Proto
=====
  0      1   0   500000  --    4G  No_Module  FC
  1      1   1   500100  --    4G  No_Module  FC
  2      1   2   500200  --    4G  No_Module  FC
  3      1   3   500300  --    4G  No_Module  FC
  4      1   4   500400  --    4G  No_Module  FC
(output truncated)
```

4. Verify that all the IP address information is correct by entering **ipAddrShow** and checking the results against the IP information recorded in the config-miscinfo.txt file.

```
switch:admin> ipaddrshow
SWITCH
Ethernet IP Address: xxx.xxx.xxx.12
Ethernet Subnetmask: 255.55.0.0
Fibre Channel IP Address: 1.2.3.4
Fibre Channel Subnetmask: 255.255.255.0
CP0
Ethernet IP Address: xxx.xxx.xxx.10
Ethernet Subnetmask: 255.55.0.0
HostName : cp0
Gateway Address: xxx.xxx.xxx.1
CP1
Ethernet IP Address: xxx.xxx.xxx.11
Ethernet Subnetmask: 255.55.0.0
HostName : cp1
Gateway Address: .1
Backplane IP address of CP0 : 10.0.0.4
Backplane IP address of CP1 : 10.0.0.5
switch:admin>switch:admin>
```

Reconnecting the system to the network and fabric

Refer to the cable routing information recorded in [Cable routing table](#) on page 123 for the following steps.

Complete the following steps to reconnect the Brocade DCX 8510-8 to the network and fabric.

1. Connect the CP blades to the local area network.
 - a) Insert the appropriate Ethernet cables into each Ethernet port.
 - b) Connect the other ends to an Ethernet 10/100 Base-T LAN, if not already connected.

NOTE

The Brocade DCX 8510-8 can be accessed by remote connection using any of the available management tools, such as Telnet or Web Tools. Ensure that the Brocade DCX 8510-8 is not modified using other connections during the rest of this procedure.

2. Reconnect the transceivers and cables to the port blades.

NOTE

The ports and cables used in trunking groups must meet specific requirements. For a list of these requirements, refer to the *Fabric OS Administrator's Guide*.

- a) Position one of the transceivers so that the key is oriented correctly to the port and insert the transceiver into the port until it is firmly seated and the latching mechanism clicks.
- b) Select the cable that corresponds to the port and position it so that the key (the ridge on one side of the cable connector) is aligned with the slot in the transceiver. Insert the cable into the transceiver until the latching mechanism clicks.
- c) Repeat step a and step b for the remaining ports.
- d) Organize the cables as required.

NOTE

Do not route cables in front of the air exhaust vents.

Verifying correct configuration of the fabric

Copying the command outputs from this section into a file is recommended.

1. Create an "after" SAN profile by entering the following commands and copying the output to a text file named SANafter.txt:

- **nsShow**
- **nsAllShow**
- **switchShow**
- **fabricShow**
- **lscfg --show** (if using the Virtual Fabric feature)

```
switch:admin> nsshows
Type Pid   COS      PortName  NodeName  TTL(sec)
N    020f00;  3;10:00:00:01:73:00:29:46;10:00:00:01:73:00:29:46; na
      Fabric Port Name: 20:0f:00:60:69:90:03:f0
<output truncated>
switch:admin> nsallshow
{
```

```

020f00 021fda 021fdc 021fe0 021fe1
5 Nx_Ports in the Fabric}
switch:admin> switchshow
switchName: rsl8-st03-dcx-01
<output truncated>
switch:admin> fabricshow
Switch ID Worldwide Name Enet IP Addr FC IP Addr Name
<output truncated>
switch:admin>lscfg --show
Created switches: 128(ds) 1 2(bs)
Port          0    1    2    3    4    5    6    7    8    9
-----
FID           1 | 1 | 1 | 1 | 1 | 128 | 128 | 128 | 128 |
<output truncated>
switch:admin>

```

2. Determine any differences between the information in the SANafter.txt file and the information in the SANbefor.txt file created earlier. In particular, look for differences in the following:
 - Device types
 - Number of devices
 - ISL and port states
 - Number of switches in the fabric
3. Resolve any issues or unintentional changes to the Brocade DCX 8510-8 or fabric:
 - If there are any mechanical problems, try reseating the associated component.
 - If the configuration information is not correct for the Brocade DCX 8510-8, modify as required.
 - If other issues exist, contact your support provider.

Cable routing table

The following table is a 64-port template for a cable routing table. Make copies of the table to cover the total number of ports in the Brocade DCX 8510-8.

TABLE 16 Cable routing table for Brocade DCX 8510-8 (64 ports shown)

| Slot/port | | Cable labels | | Connected device | Slot/port of device |
|-----------|------|--------------|------------|------------------|---------------------|
| Slot | Port | Switch end | Device end | | |
| | 0 | | | | |
| | 1 | | | | |
| | 2 | | | | |
| | 3 | | | | |
| | 4 | | | | |
| | 5 | | | | |
| | 6 | | | | |
| | 7 | | | | |
| | 8 | | | | |
| | 9 | | | | |

TABLE 16 Cable routing table for Brocade DCX 8510-8 (64 ports shown) (Continued)

| Slot/port | Cable labels | Connected device | Slot/port of device |
|-----------|--------------|------------------|---------------------|
| 10 | | | |
| 11 | | | |
| 12 | | | |
| 13 | | | |
| 14 | | | |
| 15 | | | |
| 16 | | | |
| 17 | | | |
| 18 | | | |
| 19 | | | |
| 20 | | | |
| 21 | | | |
| 22 | | | |
| 23 | | | |
| 24 | | | |
| 25 | | | |
| 26 | | | |
| 27 | | | |
| 28 | | | |
| 29 | | | |
| 30 | | | |
| 31 | | | |
| 32 | | | |
| 33 | | | |
| 34 | | | |
| 35 | | | |

TABLE 16 Cable routing table for Brocade DCX 8510-8 (64 ports shown) (Continued)

| Slot/port | Cable labels | Connected device | Slot/port of device |
|-----------|--------------|------------------|---------------------|
| 36 | | | |
| 37 | | | |
| 38 | | | |
| 39 | | | |
| 40 | | | |
| 41 | | | |
| 42 | | | |
| 43 | | | |
| 44 | | | |
| 45 | | | |
| 46 | | | |
| 47 | | | |
| 48 | | | |
| 49 | | | |
| 50 | | | |
| 51 | | | |
| 52 | | | |
| 53 | | | |
| 54 | | | |
| 55 | | | |
| 56 | | | |
| 57 | | | |
| 58 | | | |
| 59 | | | |
| 60 | | | |
| 61 | | | |

TABLE 16 Cable routing table for Brocade DCX 8510-8 (64 ports shown) (Continued)

| Slot/port | Cable labels | Connected device | Slot/port of device |
|-----------|--------------|------------------|---------------------|
| 62 | | | |
| 63 | | | |

Application and Encryption Blades

- [Introduction.....](#) 127
- [FS8-18 blade.....](#) 127
- [FX8-24 blade.....](#) 127
- [FCOE10-24 blade.....](#) 129

Introduction

This appendix provides details about the application and encryption blades that are available optionally for the Brocade DCX 8510-8. Contact your Brocade DCX 8510-8 supplier for additional information.

FS8-18 blade

The FS8-18 encryption blade is a high performance 16-port autosensing blade with data cryptographic (encryption/decryption) and data compression capabilities designed for enterprises to secure their data against theft or unauthorized use and to compress tape data for maximum utilization of tape media. The encryption blade is a network-based solution that secures data-at-rest for heterogeneous tape drives, disk array LUNs, and virtual tape libraries.

The FS8-18 blade provides the following major features:

- 16 autosensing F_Ports, FL_Ports, E_Ports, EX_Ports, and M_Ports
- 16 SFP media interfaces
- Encryption engines
- Key management/generation
- Key management with these hardware interfaces:
 - Two 1000Base copper type media interfaces
 - One smart card interface
- Security supervisor tamper detection and response capability
- Common Criteria (CC) EAL-3 compliant

FX8-24 blade

The FX8-24 blade has 12 external Fibre Channel (FC) SFP ports supporting the Fibre Channel Routing Services and 10 external 1 Gigabit Ethernet (GbE or GE) SFP ports supporting the Fibre Channel Over IP (FCIP) feature. There are also 2 licensable external 10 Gigabit Ethernet (10 GbE or 10 GE) SFP ports supporting FCIP. It operates with the Brocade Fabric Operating System and can communicate with another FX8-24 or a Brocade 7800 for both Fibre Channel Routing Services and FCIP, or a Brocade AP7420 for Fibre Channel Routing Services. The GbE ports on the FX8-24 are not compatible with the GbE ports on the FR4-18i blade, the Brocade 7500 switch, and the Brocade 7840 switch.

NOTE

The port diagram on the front panel uses the abbreviations GE for 1 GbE ports and 10GE for 10 GbE ports.

NOTE

The 10 GbE SFPs used in the FX8-24 blade and the 10 Gbps FC SFPs used in the FC16-32/48 blades are not interchangeable.

The FX8-24 operates in one of three modes: 1) ten 1 GbE ports, 2) ten 1 GbE ports and one 10 GbE port, or 3) two 10 GbE ports depending on licensing and subsequent configuration of GbE port mode. If operating in 10 GbE mode, the other end of the circuit must also be an FX8-24 operating in either 10 GbE mode or dual mode with the corresponding VE_ports in 10 GbE mode. All GbE ports on the blade can be configured to work with either copper or optical SFPs.

The FX8-24 blade is intended as a platform for FCIP and Fibre Channel Routing Services. Refer to the *Fabric OS Administrator's Guide* for information on configuring these features.

The FX8-24 blade provides the following hardware features:

- 12 autosensing FC ports with link speeds of 1, 2, 4, or 8 Gbps
- Ten GbE ports supporting FCIP with fixed link speed at 1 Gbps
- Two 10 GbE ports (licensable) supporting FCIP with fixed link speed at 10 Gbps

The FX8-24 blade also provides the following functionality features:

- FCIP
- Compression (on FC frames before FCIP encapsulation)
- FC Routing (licensable)
- FCIP Trunking (licensable) with network-based failure recovery (failover only) and load balancing
- Multiple circuits per trunk:
 - Four per trunk through the GbE ports
 - Ten per trunk through the 10 GbE ports
- SO-TCP with reorder resistance
- FastWrite over FCIP
- Tape pipelining over FCIP
- FICON XRC emulation and tape pipelining over FCIP (licensable)
- FICON CUP (licensable)
- Virtual E_Ports
- FCIP QoS
- Support for 200 ms RTT (on a limited number of GbE ports)
- Adaptive Rate Limiting (licensable)
- TCP performance graphing in Web Tools
- FCIP Tunnels:
 - A maximum of 10 FCIP Tunnels for all GbE ports
 - Four tunnels maximum per GbE port
 - Two 10 GbE ports can support up to ten FCIP tunnels each
 - Each FCIP tunnel is represented and managed as a virtual Fibre Channel E_Port
 - Fibre Channel Routing Services can be used over the FCIP link

- The Link Cost is equal to the sum of all established/low metric (or currently active) circuits' MAX rates in the tunnel.
- Fabrics connected through FCIP merge if the ports are configured as VE_Ports, and do not merge if they are configured as VEX_Ports. If VE_Ports are used in a Fibre Channel Routing Services backbone fabric configuration, then the backbone fabric merges, but the EX_Port-attached edge fabrics do not merge. For more information, refer to the *Fabric OS Administrator's Guide*.
- Up to three FC trunking groups:
 - Trunk group 0: FC ports 0, 1
 - Trunk group 1: FC ports 6, 7
 - Trunk group 2: FC ports 2, 3, 4, 5, 8, 9, 10, 11

FCOE10-24 blade

The FCOE10-24 blade has 24 Fibre Channel over Ethernet (FCoE) ports that enable the transmission of FC frames over an Ethernet network via encapsulation in standard Ethernet packets. This is enabled by adherence to Converged Enhanced Ethernet (CEE) standards, a low latency, lossless Ethernet standard. This does not require dedicated Ethernet lines, but rather can make use of existing Ethernet infrastructure to reduce costs.

NOTE

This blade cannot be used in the same chassis with an FC8-48E, FC8-64, FC16-48, FC16-64 port blades or any of the application blades (FA4-18, FR4-18i, FX8-24, FS8-18).

The FCOE10-24 blade supports only optical cabling and transceivers (SFP+).

There are no licensing requirements for functionality on this blade.

The FCOE10-24 blade provides the following hardware features:

- 24 FCoE ports operating at 10 Gbps
- 32 FC ports operating at 8 Gbps through the backplane
- Hot pluggable
- I²C Management interface through the backplane
- JTAG support
- Blade power and status LEDs
- Link status LEDs per port

The FCOE10-24 blade also provides the following functionality features:

- FCoE switching
- CEE switching
- Standard Ethernet encapsulation
- End of row deployment

NOTE

With the switch in online state, if all the FCOE ports are shutdown, offline diags will continue to run. After this, the blade will be in inoperable state and you need to issue **slotpoweroff** and **slotpoweron** to recover.

Refer to the *Fabric OS Administrator's Guide* for information on configuring these features.

Limitations of FCOE10-24 blade

The following limitations have to be considered when using FCOE10-24 application blade with Fabric OS 7.3.0, on the DCX 8510-8 chassis:

- FCOE10-24 blade is supported only in slot 1 of the 8510-8 chassis.
- Supports maximum of one FCOE10-24 blade per 8510-8 chassis.
- FCOE10-24 blade can be installed concurrently with FC16-32 and FC8-32E blades only.
- FCOE10-24 blade cannot be used in the DCX 8510-8 chassis with FC16-48, FC16-48E, FC8-64 or FC16-64 blades.
- FCOE10-24 blade cannot be used in a DCX 8510-8 chassis with other intelligent or application blades.
- Support is limited to FCoE direct attach only.
- Upgrade and downgrade considerations are same as DCX.

NOTE

For complete list of limitations on the FCOE10-24 blade, refer to the Fabric OS Release Notes.

Diagnostics and Troubleshooting

- [Introduction](#)..... 131
- [Obtaining chassis and component status](#)..... 131
- [Interpreting POST and boot results](#)..... 132
- [Diagnostics](#)..... 133
- [Troubleshooting](#)..... 134

Introduction

For information about troubleshooting the entire fabric, refer to the *Fabric OS Troubleshooting and Diagnostics Guide*.

The Brocade DCX 8510-8 includes a number of diagnostic aids to assist with troubleshooting, including LEDs on the hardware, commands that display current status, diagnostic tests for hardware and software, and error messages. In addition, a number of managing and monitoring features are available, such as Fabric Manager, Web Tools, Fabric Watch, and Advanced Performance Monitoring.

If the Brocade DCX 8510-8 does not operate as expected, the following steps can be taken to diagnose the problem:

- Check the LEDs and refer to the LED tables ([Monitoring System Components](#) on page 49) for interpretation and recommended actions.
- Review the results of the last POST run by the Brocade DCX 8510-8 ([Interpreting POST and boot results](#) on page 132).
- Review the error logs. (Refer to the *Fabric OS Troubleshooting and Diagnostics Guide* for more information).
 - Review RASlog entries.
 - Use the **sensorShow** command to determine the status of the hardware components.
 - Run diagnostic tests ([Diagnostics](#) on page 133).
 - Reboot the Brocade DCX 8510-8 or power the entire chassis off and then on ([Powering off the Brocade DCX 8510-8](#) on page 48 and [Providing power to the Brocade DCX 8510-8 Backbone](#) on page 27).

If the problem is still unresolved after these steps, contact your support provider.

Obtaining chassis and component status

The CLI commands in the following table provide status and environmental information about the chassis and its components. These commands provide information only, and they do not interrupt traffic flow. For more information about these commands, refer to the *Fabric OS Command Reference*.

TABLE 17 Environmental status and maintenance commands

| Command | Information displayed |
|-----------------------|---|
| sensorShow | Temperature readings for the port blades |
| | Temperature readings for the CP blades |
| | Status and RPM of all operational fans |
| | Status of all operational power supplies |
| tempShow | Temperature readings for the port blades |
| | Temperature readings for the CP blades |
| psShow | Status of all operational power supplies |
| fanShow | Status and RPM of all operational fans |
| chassisShow | Serial number, time awake, and additional information about each component |
| slotShow | Slot occupancy |
| errShowerrDump | System error log. Refer to the <i>Fabric OS Message Reference</i> for more information on the messages in this log. |

Interpreting POST and boot results

The Brocade DCX 8510-8 performs Power-On Self-Test (POST) by default each time the chassis is powered on, rebooted, or reset. The Brocade DCX 8510-8 can be rebooted using the **reboot** (to reboot each CP individually) or **fastBoot** commands. The **fastBoot** command reboots the switches without running POST. If the active CP blade is rebooted, it fails over to the standby CP blade.

POST

The Brocade DCX 8510-8 automatically performs POST each time it is powered on or reset.

To verify that POST has completed without error, do the following:

- Verify that all LEDs return to a normal state after POST completes.

If one or more LEDs do not return to a normal state, and this is not due to the Brocade DCX 8510-8 being set to beacon, refer to the relevant LED table to identify and correct the problem. For port blades, and CP and core switch blades, the **slotShow** command can be used to check the status of the slots. For information about turning beaconing on or off, refer to the *Fabric OS Administrator's Guide*.

- Verify that the switch prompt displays when POST completes.

If it does not display, POST was not successfully completed. Contact the Brocade DCX 8510-8 supplier for support.

- Review the system error log using the **errShow** or **errDump** commands.

Any errors detected during POST are written to the system log, which is accessible through the **errShow** command. For information about error messages, refer to the *Fabric OS Message Reference*.

POST includes the following steps:

1. Preliminary POST diagnostics are run.
2. Operating system is initialized.
3. Hardware is initialized.
4. Diagnostic tests are run on several functions, including circuitry, port functionality, ability to send and receive frames, all aspects of memory, parity, statistics counters, and serialization.

Boot

In addition to POST, boot includes the following steps after POST is complete:

1. Universal port configuration is performed.
2. Links are initialized.
3. Fabric is analyzed. If any ports are connected to other switches, the Brocade DCX 8510-8 participates in a fabric configuration.
4. The Brocade DCX 8510-8 obtains a domain ID and assigns port addresses.
5. Unicast routing tables are constructed.
6. Normal port operation is enabled.

Diagnostics

Diagnostic tests are automatically run during POST to check the status of the Brocade DCX 8510-8. Any error messages generated during POST are sent to the error logs and to the serial console, if connected.

Diagnostic tests can also be run manually to test and troubleshoot the hardware and the firmware, including internal connections and circuitry, transceivers, and port cables. However, diagnostic tests are generally intended for use by support personnel.

NOTE

Error messages do not necessarily indicate that the Brocade DCX 8510-8 requires maintenance.

Each diagnostic test can be implemented by entering the related command through a Telnet or serial session. For a list of diagnostic tests and commands, refer to the *Fabric OS Administrator's Guide*.

All diagnostic tests are run at all supported link speeds. They might temporarily lock the transmit and receive speeds to a specific speed. Some diagnostic tests require interconnecting the ports to each other or using loopback plugs. If ports are interconnected, the media (cables and transceivers) at each end of the connection must be of the same type. For example, short wavelength media must be connected to short wavelength media, and likewise with long wavelength media and copper media.

For more information about diagnostic tests and how to run them, refer to the *Fabric OS Administrator's Guide* and the *Fabric OS Command Reference*. For information about system error messages (**errShow** or **errDump**), refer to the *Fabric OS Troubleshooting and Diagnostics Guide*.

Troubleshooting

The following table provides a list of issues, possible causes, and recommended actions.

TABLE 18 Troubleshooting the Brocade DCX 8510-8

| Issue | Possible cause | Recommended action |
|--|--|--|
| Entire chassis powers off automatically. | Power supplies are inadequate to support the installed components. | Add an additional power supply. |
| Several or all components are not operating. | One or both power cables may not be connected to a live source. | Ensure that both power cables are connected to live outlets. |
| | One or both AC power switches might be off. | Ensure that both AC power switches are on (AC switches light up green when on). |
| Serial connection is faulty or serial port logs have incorrect or missing information. | Serial cable is not connected correctly. | Ensure that the cable is firmly connected to workstation computer and to the Brocade DCX 8510-8. |
| | Terminal emulator application parameters are not set correctly. | Ensure that the terminal emulator application is configured as follows: 9600 bits per second, 8 databits, no parity, 1 stop bit, no flow control. |
| | Serial port might be incompatible (only RS-232 is supported). | Ensure that the Brocade DCX 8510-8 is connected to an RS-232 port. RS-232 serial ports might experience difficulties due to corner-case incompatibilities of the standards. |
| | Pins on the serial cable or serial port might be damaged. | Remove the cable and inspect the pins on the cable and in the serial port. Do not reinstall if the pins on either component have any visible damage, as this could damage the pins on the other component. Replace the components as required. |
| CP Ethernet link speed is different than expected or a link cannot be established. | There might be a conflict with the CP Ethernet link speed negotiation set up by the network. | Specify the CP Ethernet link speed by typing the ifModeSet command. For more information about Ethernet connectivity to the Brocade DCX 8510-8, refer to the LAN guidelines provided through the MyBrocade website. |
| Configuration data is inaccurate or cannot be accessed. | Chassis was powered off/on while a WWN card was uninstalled or failed. | Install an operational WWN card and power the system off/on again. |
| | The Brocade DCX 8510-8 was rebooted while an WWN card was uninstalled or failed. | |
| Initial setup results in IP address/Domain ID conflict. | The Brocade DCX 8510-8 was connected to the fabric before being configured. | Refer to the <i>Fabric OS Administrator's Guide</i> for configuration information. |

TABLE 18 Troubleshooting the Brocade DCX 8510-8 (Continued)

| Issue | Possible cause | Recommended action |
|---|---|---|
| LEDs on one or more components are changing rapidly or do not indicate a healthy state. | The Brocade DCX 8510-8 might be booting or running POST. | Verify that boot and POST are complete. The Brocade DCX 8510-8 requires a minimum of 3 minutes, usually, after power-on to complete POST. |
| | Beaconing might be on for the entire Brocade DCX 8510-8 or for individual components. | Determine whether beaconing is on by typing the switchShow command and determine whether switch beaconing or blade beaconing are on. |
| | Individual components might have failed. | Refer to the LED tables in Monitoring System Components on page 49 for interpretation and recommended actions. |
| | Pins on the components might be damaged. | Remove the component from the chassis and inspect the pins on the component and inside the chassis. Do not reinstall if pins on either component are damaged, as this could damage pins on other components. Replace the parts as required. |
| None of the LEDs on a component are on. | Component might not be seated correctly. | Ensure that the Brocade DCX 8510-8 has power and the component is firmly seated. If the problem continues, enter the sensorShow command to determine the component status. If the component is a CP blade or port blade, enter the slotShow command to determine the status. |
| | Component might have failed. | Replace the component as necessary. |
| CP blades are failing over frequently. | There is excessive serial port activity. | Ensure that the serial port activity remains below specified amount. |
| | CP blade is attached to an Ethernet with high traffic loads. | Ensure that the Ethernet traffic remains below specified amount |
| | Chassis is overheated. | Enter the tempshow and sensorShow commands to check internal temperature. If components are overheating, shut down port blades as necessary to return the temperature to operating range. Also try moving the blades in the chassis replace it is possible that airflow might not be adequate to cool everything in certain configurations. |
| One or more port blades have either shut down or failed POST as indicated by the error log. | Blades might be overheated. | Enter the sensorShow command to check the internal temperature readings. If components are overheating, shut down port blades as necessary to return the temperature readings to the operating ranges. Also try moving the blades in the chassis because it is possible that airflow might not be adequate to cool everything in certain configurations. |

TABLE 18 Troubleshooting the Brocade DCX 8510-8 (Continued)

| Issue | Possible cause | Recommended action |
|---|---|--|
| | Blades might be faulty. | Enter the slotShow command to determine status. For more information, enter the diagDisablePost command; then, use the slotPowerOff [slot number] and slotPowerOn [slot number] command. Resolve the source of the problem or replace the blade as required. |
| | Pins on the blade or the backplane might be damaged. | Remove the blade from the chassis and inspect the pins on the blade and on the backplane inside the slot. Do not reinstall if the pins on either component are damaged, as this could damage pins on other components. Replace the components as required. |
| An individual component is not operating as expected. | Component may not have power or may not be firmly seated. | Ensure that the component is receiving power (power LED should be on) and the component is firmly seated. |
| | Pins on the component or the backplane might be damaged. | Remove the component from the chassis and inspect the pins on the blade and inside the chassis. Do not reinstall if the pins on either component are damaged, as this could damage pins on other components. Replace parts as required. |
| | The component might have failed. | Enter the tempshow and sensorShow command to determine the component status. If the component is a CP blade or port blade, enter the slotShow command to determine the status. Replace the component as necessary. |

Port Numbering Template

Print or copy the following templates in this appendix and use them to document the port numbering pattern for the Brocade DCX 8510-8. These templates show the following blades:

- CR16-8 core blade
- FC8-32E port blade
- FC8-48E port blade
- FC8-64 port blade
- FC16-32 port blade
- FC16-48 port blade
- FC16-64 port blade
- FCOE10-24 application blade
- FS8-18 encryption blade
- FX8-24 extension blade

FIGURE 41 CR16-8 core blade

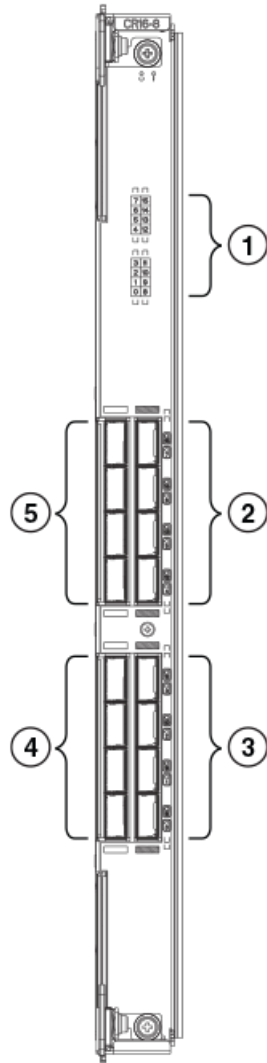

1. Port map
2. QSFP ports 12-15 (bottom to top)
3. QSFP ports 8-11 (bottom to top)
4. QSFP ports 0-3 (bottom to top)
5. QSFP ports 4-7 (bottom to top)

The following table shows the mappings from the numbered ports on the face of the core blade to the port mappings as shown by the **slotShow** command. Each external port maps to four actual ports.

TABLE 19 External port to slotShow port mapping for core blades

| External port number | slotShow port numbers | External port number | slotShow port numbers |
|----------------------|-----------------------|----------------------|-----------------------|
| 0 | 0-3 | 8 | 32-35 |
| 1 | 4-7 | 9 | 36-39 |

TABLE 19 External port to slotShow port mapping for core blades (Continued)

| External port number | slotShow port numbers | External port number | slotShow port numbers |
|----------------------|-----------------------|----------------------|-----------------------|
| 2 | 8-11 | 10 | 40-43 |
| 3 | 12-15 | 11 | 44-47 |
| 4 | 16-19 | 12 | 48-51 |
| 5 | 20-23 | 13 | 52-55 |
| 6 | 24-27 | 14 | 56-59 |
| 7 | 28-31 | 15 | 60-63 |

FIGURE 42 FC8-32E port blade

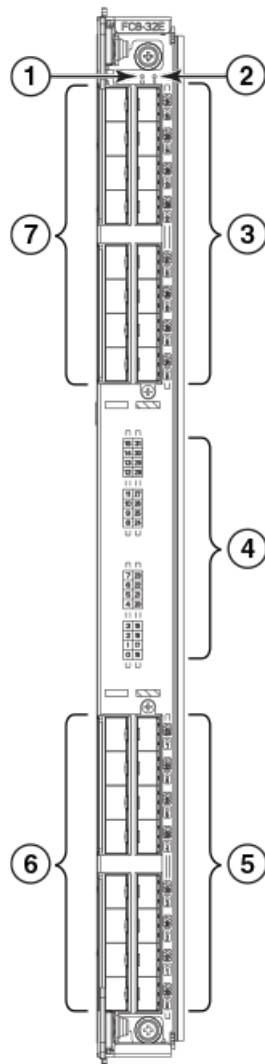

1. Blade power LED
2. Blade status LED
3. FC ports 24-31
4. Port and trunking group map
5. FC ports 16-23
6. FC ports 0-7
7. FC ports 8-15

FIGURE 43 FC8-48E port blade

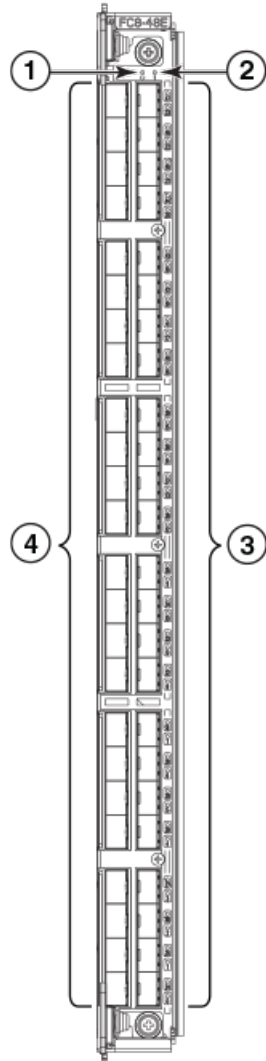

1. Blade power LED
2. Blade status LED
3. FC ports 24-47
4. FC ports 0-23

FIGURE 44 FC8-64 port blade

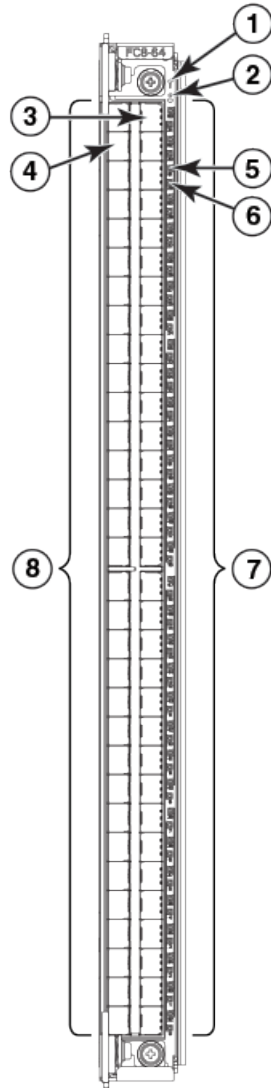

1. Blade status LED
2. Blade power LED
3. Port 63
4. Port 30
5. Port 61 status LED
6. Port 29 status LED
7. FC ports 32-63 (bottom to top)
8. FC ports 0-31 (bottom to top)

FIGURE 45 FC16-32 port blade

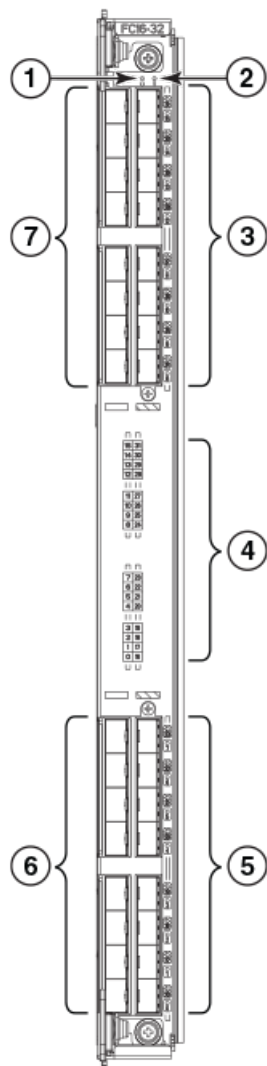

1. Blade power LED
2. Blade status LED
3. FC ports 24-31
4. Port and trunking group map
5. FC ports 16-23
6. FC ports 0-7
7. FC ports 8-15

FIGURE 46 FC16-48 port blade

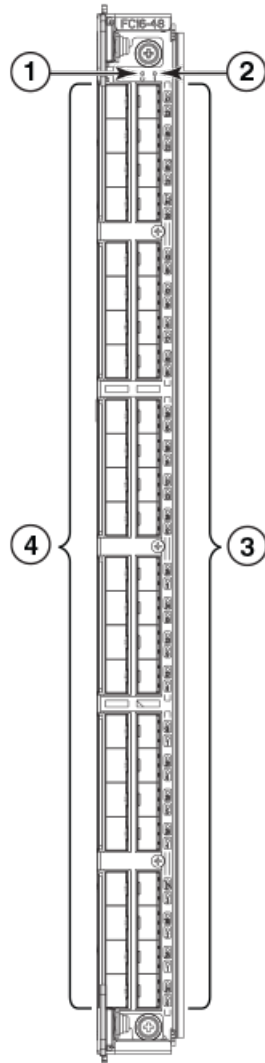

- 1. Blade power LED
- 2. Blade status LED
- 3. FC ports 24-47
- 4. FC ports 0-23

FIGURE 47 FC16-64 port blade

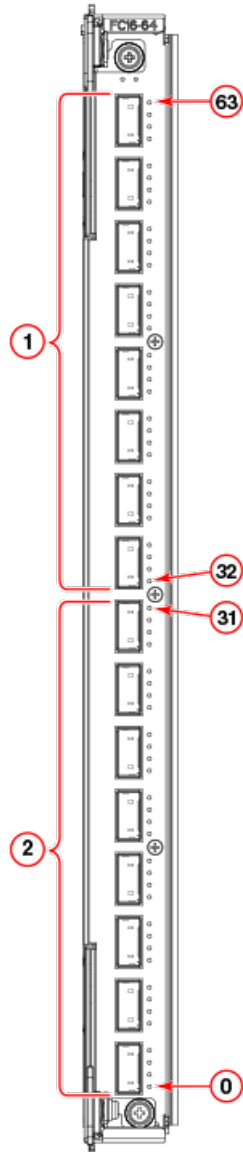

1. QSFP ports 8-15; FC ports 32-63 (bottom to up)
2. QSFP ports 0-7; FC ports 0-31 (bottom to up)

FIGURE 48 FS8-18 encryption blade

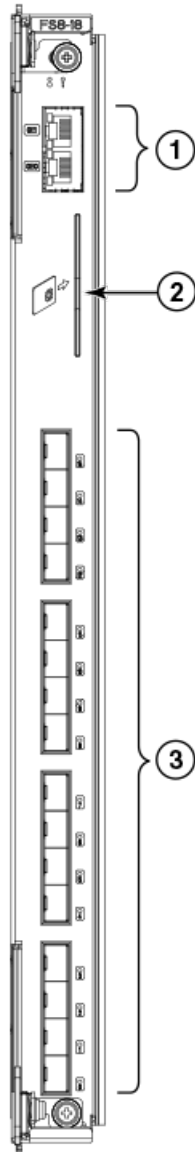

1. Gigabit Ethernet ports GE0-GE1
2. Smart card port
3. Fibre Channel ports 0-15

FIGURE 49 FX8-24 extension blade

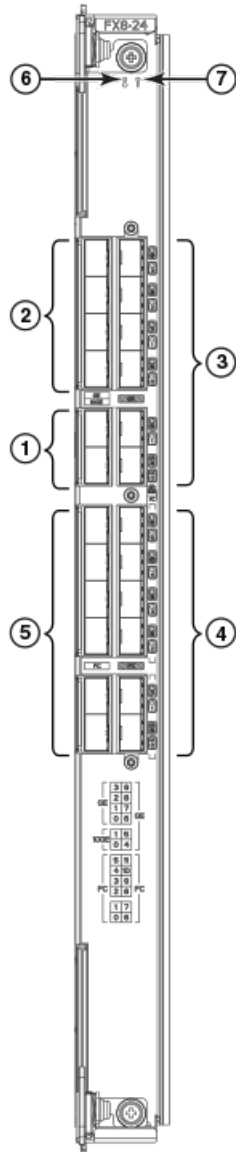

- 1. 10 GbE ports 0-1
- 2. 1 GbE ports 0-3
- 3. 1 GbE ports 4-9
- 4. FC ports 6-11
- 5. FC ports 0-5
- 6. Blade Power LED
- 7. Blade Status LED

FIGURE 50 FCOE10-24 FCoE blade

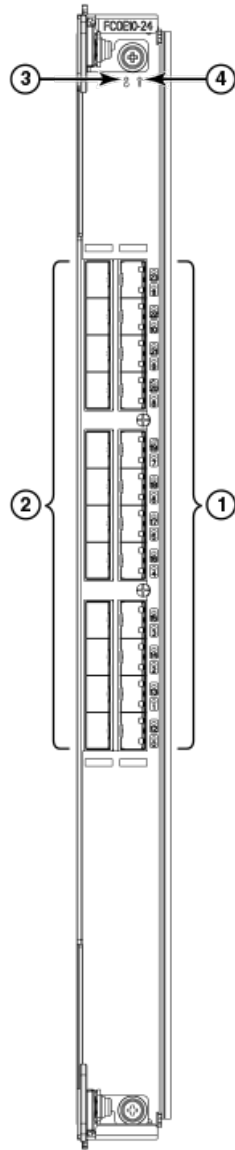

- 1. 10-GbE CEE ports 12-23
- 2. 10-GbE CEE ports 0-11
- 3. Power LED
- 4. Status LED

Regulatory Statements

- [Regulatory compliance](#)..... 149
- [Environmental regulation compliance](#)..... 152

Regulatory compliance

- [FCC warning \(US only\)](#) on page 149
- [KCC statement \(Republic of Korea\)](#) on page 149
- [VCCI statement \(Japan\)](#) on page 149
- [Power-cord notice \(Japan, Denan\)](#) on page 150
- [BSMI statement \(Taiwan\)](#) on page 150
- [CE statement](#) on page 150
- [Canadian requirements](#) on page 151
- [German statement](#) on page 151
- [Regulatory compliance standards](#) on page 151

FCC warning (US only)

This equipment has been tested and complies with the limits for a Class A computing device pursuant to Part 15 of the FCC Rules. These limits are designed to provide reasonable protection against harmful interference when the equipment is operated in a commercial environment.

This equipment generates, uses, and can radiate radio frequency energy, and if not installed and used in accordance with the instruction manual, might cause harmful interference to radio communications. Operation of this equipment in a residential area is likely to cause harmful interference, in which case the user will be required to correct the interference at the user's own expense.

KCC statement (Republic of Korea)

A급 기기 (업무용 방송통신기기): 이 기기는 업무용(A급)으로 전자파적합등록을 한 기기이오니 판매자 또는 사용자는 이 점을 주의하시기 바라며, 가정외의 지역에서 사용하는 것을 목적으로 합니다.

Class A device (Broadcasting Communication Device for Office Use): This device obtained EMC registration for office use (Class A), and may be used in places other than home. Sellers and/or users need to take note of this.

VCCI statement (Japan)

This is a Class A product based on the standard of the Voluntary Control Council for Interference by Information Technology Equipment (VCCI). If this equipment is used in a domestic environment, radio disturbance might arise. When such trouble occurs, the user might be required to take corrective actions.

この装置は、クラスA情報技術装置です。この装置を家庭環境で使用すると電波妨害を引き起こすことがあります。この場合には使用者が適切な対策を講ずるよう要求されることがあります。 VCCI-A

Power-cord notice (Japan, Denan)



注意 - 添付の電源コードを他の装置や用途に使用しない
添付の電源コードは本装置に接続し、使用することを目的として設計され、その安全性が確認されているものです。決して他の装置や用途に使用しないでください。火災や感電の原因となる恐れがあります。



DANGER

Never use the power cord packed with your equipment for other products.

BSMI statement (Taiwan)

警告使用者：

這是甲類的資訊產品，在居住的環境中使用時，可能會造成射頻干擾，在這種情況下，使用者會被要求採取某些適當的對策。

Warning:

This is Class A product. In a domestic environment, this product may cause radio interference, in which case the user may be required to take adequate measures.

CE statement

This is a Class A product. In a domestic environment, this product might cause radio interference, and the user might be required to take corrective measures.

The standards compliance label on the product contains the CE mark which indicates that this system conforms to the provisions of the following European Council directives, laws, and standards:

- Electromagnetic Compatibility (EMC) Directive 2004/108/EEC
- Low Voltage Directive (LVD) 73/23/EEC and the Complementary Directive 93/68/EEC
- EN55022:2006 (European Emissions Requirements)
- EN55024:1998, +A1:2001 and +A2:2003 (European Immunity Requirements)
- EN61000-3-2:2006/IEC61000-3-2:2006 (European and Japanese Harmonics Spec)
- EN61000-3-3:1995, +A1:2001 and +A2:2005

Canadian requirements

This Class A digital apparatus meets all requirements of the Canadian Interference-Causing Equipment Regulations, ICES-003 Class A.

German statement

Maschinenlärminformations-Verordnung - 3 GPSGV, der höchste Schalldruckpegel beträgt 79.0 dB(A) gemäss EN ISO 7779.

Machine noise information regulation - 3. GPSGV, the highest sound pressure level value is 79.0 dB(A) in accordance with EN ISO 7779.

Regulatory compliance standards

The following table lists the regulatory compliance standards for which the Brocade DCX 8510-8 is certified.

TABLE 20 Regulatory compliance standards

| Country | Standards | | Agency Certifications and Markings | |
|------------------------|--|---------------------------------------|------------------------------------|---------------------------|
| | Safety | EMC | Safety | EMC |
| United States | Bi-Nat UL/CSA 60950-1 2nd Ed or latest | ANSI C63.4 | cCSAus | FCC Class A and Statement |
| Canada | Bi-Nat UL/CSA 60950-1 2nd Ed or latest | ICES-003 Class A | cCSAus | ICES A and Statement |
| Japan | | CISPR22 and JEIDA (Harmonics) | | VCCI-A and Statement |
| European Union | EN60950-1 2nd Ed or latest | EN55022 and EN55024 | TUV-GS, N | CE marking |
| Australia, New Zealand | | EN55022 or CISPR22 or AS/NZS CISPR22 | | C-Tick mark |
| Argentina | IEC60950-1 2nd Ed or latest | | "S" mark | |
| Russia | IEC60950-1 2nd Ed or latest | 51318.22-99 and 51318.24-99 or latest | GOST mark | GOST mark |
| Korea | | KN22 and KN24 | | KC mark Class A |
| China (PS only) | GB4943-2001 and GB9254-1998 or latest | GB17625.1-2012 or latest | CCC logo | CCC logo |

TABLE 20 Regulatory compliance standards (Continued)

| Country | Standards | Standards | Agency Certifications and Markings | |
|------------------|-------------------------|-------------------------|------------------------------------|-----------|
| Taiwan (PS only) | CNS 14336(94) or latest | CNS 13438(95) or latest | BSMI mark | BSMI mark |

Environmental regulation compliance

- [China RoHS](#) on page 152

China RoHS

Refer to the latest revision of the China ROHS document (P/N 53-1000428-xx) which ships with the product.

Brocade DCX 8510 Technical Specifications

This document highlights the features and specifications for the Brocade DCX 8510-4 and the Brocade DCX 8510-8 switches.

System specifications

| System component | Description |
|---------------------------|--|
| Enclosure | Brocade DCX 8510-4 - 8U rack-mountable chassis; 1U exhaust shelf Brocade DCX 8510-8 - 15U rack-mountable chassis |
| Control processor | Redundant (active/standby) control processor blades |
| Scalability | Full fabric architecture: a maximum of 239 switches |
| Performance | <ul style="list-style-type: none">• 2.125 Gbps line speed, full duplex• 4.25 Gbps line speed, full duplex• 8.50 Gbps line speed, full duplex• 10.51875 Gbps line speed, full duplex• 16 Gbps line speed, full duplex Autosensing of 2, 4, 8, and 16 Gbps port speeds depending on SFPs used. Speed matching between 2, 4, 8, and 16 Gbps port speeds. 10 Gbps port speeds with dedicated SFPs. |
| ISL Trunking | Automatically uses up to 4 ports in a QSFP to form a 64 Gbps trunk. Can use up to 8 ports in a trunk group to form a 128 Gbps trunk. |
| Chassis bandwidth | Brocade DCX 8510-4: 4.1 Tbps per chassis (192 ports × 16 Gbps data rate + 1.024 Tbps UltraScale ICL bandwidth) Brocade DCX 8510-8: 8.2 Tbps per chassis (384 ports × 16 Gbps data rate + 2.048 Tbps UltraScale ICL bandwidth) |
| Slot bandwidth | 512 Gbps (data rate) |
| Local switching bandwidth | 512 Gbps for Brocade FC16-32: 32 ports × 16 Gbps (data rate) 768 Gbps for Brocade FC16-48: 48 ports × 16 Gbps (data rate) 256 Gbps for Brocade FC8-32E: 32 ports × 8 Gbps (data rate) 384 Gbps for Brocade FC8-48E: 48 ports × 8 Gbps (data rate) 512 Gbps for Brocade FC8-64: 64 ports × 8 Gbps (data rate) |

| System component | Description |
|--------------------------|--|
| UltraScale ICL bandwidth | <p>Brocade DCX 8510-4: 1.024 Tbps; 16 UltraScale ICL ports provide the equivalent of 64 16-Gbps ports. Each UltraScale ICL port provides 64 Gbps bandwidth over a QSFP (16 Gbps x 4) link.</p> <p>Brocade DCX 8510-8: 2.048 Tbps; 32 UltraScale ICL ports provide the equivalent of 128 16-Gbps ports. Each UltraScale ICL port provides 64 Gbps bandwidth over a QSFP (16 Gbps x 4) link.</p> <p>Both models: Frame-based trunking is enabled between four UltraScale ICLs. DPS distributes exchanges across all frame trunks.</p> |
| Power inlet | C13; power from non-port side |
| Power supplies | <p>Brocade DCX 8510-4 - Two hot-swappable 2000 W AC power supply modules (100-240 VAC autosensing), 2N redundancy</p> <p>Brocade DCX 8510-8 - Four modular, hot-swappable power supplies (100-240 VAC autosensing)</p> |
| Fans | <p>Brocade DCX 8510-4 - Two fans per chassis</p> <p>Brocade DCX 8510-8 - Three fans per chassis</p> |
| Cooling | <p>Brocade DCX 8510-4 - Two blower assembly modules (one required for operation); rear panel-to-door airflow</p> <p>Brocade DCX 8510-8 - Three blower assemblies; non-port (non-cable) side to the port (cable) side airflow</p> |
| System architecture | Nonblocking shared memory |
| System processors | FreeScale 8548, 1.2 GHz |
| Aggregate bandwidth | 5 Tbps populated with four FC16-64 port blades and using 16 ICL ports @ 64 Gbps |
| Switch latency | <p>FC8-32E, FC8-48E, and FC8-64 blades: <700 ns any port to any port local switching and 2.1 µsec blade to blade at 8-Gbps, cut-through routing.</p> <p>FC16-32, FC16-48, and FC16-64 blades: <700 ns any port to any port local switching and 2.1 µsec blade to blade at 16-Gbps, cut-through routing.</p> <p>FX8-24 blade - FC to FC: <2.1 µsec any port to any port at 8 Gbps, cut-through routing.</p> <p>FCOE10-24 blade - CEE to CEE (different ASIC) and FCoE to FC: <5 µsec any port to any port at 8 Gbps, cut-through routing.</p> |
| Maximum frame size | 2112-byte payload |
| Frame buffers | 8000 per Gen 5 ASIC, with 5000 more that can be borrowed from neighboring ASIC if enabled |

| System component | Description |
|--------------------|---|
| Port types | <p>FC8-32E port blade : F_Port, E_Port, EX_Port, and M_Port</p> <p>FC8-48E port blade : F_Port, E_Port, EX_Port, and M_Port</p> <p>FC8-64 port blade : F_Port, FL_Port, E_Port, EX_Port, and M_Port</p> <p>FC16-32 port blade : F_Port, E_Port, EX_Port, M_Port, and D_Port</p> <p>FC16-48 port blade : F_Port, E_Port, EX_Port, M_Port, and D_Port</p> <p>FC16-64 port blade : F_Port, E_Port, EX_Port, M_Port, and D_Port</p> <p>FS8-18 application blade : FL_Port, F_Port, E_Port, EX_Port, and M_Port</p> <p>FX8-24 application blade : F_Port, FL_Port, E_Port, and EX_Port on FC</p> <p>VE_Port on GbE</p> <p>FCOE10-24 application blade: VF_Port</p> <p>NOTE: Self-discovery is based on switch type (U_Port) with an optional port type control.</p> |
| Data traffic types | Fabric switches supporting unicast, multicast (255 groups), and broadcast |
| Media types | <p>8 Gbps: FC8-32E, -48E, and FS8-18 blade require Brocade hot-pluggable SFP+, LC connector; 8 Gbps SWL</p> <p>8 Gbps: FC8-64, requires Brocade hot-pluggable mSFP; 8 Gbps SWL only</p> <p>16 Gbps: FC16-32 and -48, require Brocade hot-pluggable SFP+; 16 Gbps, 10 Gbps, or 8 Gbps SWL and LWL</p> <p>16 Gbps: FC16-64, requires Brocade-branded, hot-pluggable QSFP; 4 Gbps, 8 Gbps, or 16 Gbps x 4 SWL only</p> <p>16 Gbps: Core blades, require Brocade-branded, hot-pluggable QSFP; 16 Gbps x 4 SWL only</p> <p>1 GbE: FX8-24 can use Brocade-branded 4 Gbps SFP</p> <p>10 GbE: FCOE10-24 blades use Brocade-branded SFP+ transceivers, either short-reach (SR) or long-reach (LR)</p> <p>Core blade (CR16-4) uses Brocade-branded, hot-pluggable QSFP; 16 Gbps x 4 SWL only for ICL connections</p> <p>Distance subject to fiber-optic cable and port speed.</p> |
| USB | One USB port per control processor for firmware download, support save, and configuration upload or download |
| Fabric Services | <p>Advanced Performance Monitoring; Adaptive Networking (Ingress Rate Limiting, Traffic Isolation, QoS); BB credit recovery; Brocade Advanced Zoning (default zoning, port/WWN zoning, broadcast zoning); Dynamic Path Selection (DPS); Extended Fabrics; Fabric Watch; FDMI; FICON CUP; Frame Redirection; FSPF; Integrated Routing (FR4-18i SAN Extension blade not required for routing); IPFC; ISL Trunking; Management Server; N_Port Trunking; NPIV; NTP v3; Port Fencing; Registered State Change Notification (RSCN); Reliable Commit Service (RCS); Simple Name Server (SNS); syslog; Top Talkers; Virtual Fabrics (Logical Switch, Logical Fabric)</p> |

| System component | Description |
|--------------------------|---|
| Extension | Supports DWDM, CWDM, and FC-SONET devices; Fibre Channel, in-flight compression (Brocade LZO) and encryption (AES-GCM-256) BB credit recovery; FCIP, Adaptive Rate Limiting (ARL), data compression, Fast Write, read/write Tape Pipelining, QoS |
| FICON | FICON cascading (Brocade Fabric OS: Brocade DCX 8510-8, DCX 8510-4); support for lossless DLS; FICON CUP; Advanced Accelerator for FICON (FICON Global Mirror and XRC emulation and read/write Tape Pipelining) The Brocade FC8-64 blade does not support FICON. |
| Inter-chassis link (ICL) | Chassis-to-chassis linkage through connectors on the core switch blade (CR16-4) |

Fibre Channel

| System component | Description |
|------------------------------|---|
| Fibre Channel ports | Brocade DCX 8510-4: Up to 256 16-Gbps ports, universal (F_Port, E_Port, EX_Port, M_Port, D_Port) Brocade DCX 8510-8: Up to 512 16-Gbps ports, universal (E_Port, F_Port, EX_Port, M_Port, D_Port, FICON) |
| Classes of service | Class 2, Class 3, Class F (interswitch frames) |
| ANSI Fibre Channel protocol | FC-PH (Fibre Channel Physical and Signalling Interface standard) |
| Modes of operation | 1) ten 1 GbE ports, 2) ten 1 GbE ports and one 10 GbE port, or 3) two 10 GbE ports depending on licensing and subsequent configuration of GbE port mode |
| Fabric initialization | Complies with FC-SW 5.0 |
| FCIP (IP over Fibre Channel) | Complies with FC-IP 2.3 of the FCA profile |
| Port to port latency | Local switching - 700 ns (any port to any port); Blade to blade - 2.1 microseconds (E_Port to E_Port) |
| Switching capacity | An aggregate switching capacity of 3.36 billion frames per second (for Class 2, Class 3, and Class F frames for a 256-port chassis) |

LEDs

| System component | Description |
|------------------------------|--|
| Switch status and management | Unicolor LED (amber) displaying four different LED states based on blade activity and status |

| System component | Description |
|------------------|---|
| Port Status | Bicolor port status LED (green and amber) displaying nine different LED states based on FC port activity and status |

Other

| System component | Description |
|----------------------|--|
| Serial Cable | RS-232 serial cable |
| RJ-45 to DB9 adapter | RS-232 cable has an adapter at one end that can be removed to provide an RJ-45 style connector |
| RJ-45 connector | Serial port 10/100/1000 Ethernet (RJ-45) per control processor |

Weight and physical dimensions

"Fully Loaded": Brocade DCX 8510-4: 256-port configuration with four FC16-64 port blades including two CP blades, two core switch blades, two blowers, two power supplies, and two cable management finger assemblies.

"Fully Loaded": Brocade DCX 8510-8: 512-port configuration with eight FC16-64 port blades including two CP blades, two core switch blades, three blowers, four power supplies, and one cable management comb.

| Model | Height | Width | Depth | Weight (empty) | Weight (fully loaded) |
|---------------------------------------|--------------|--------------|--------------|----------------|-----------------------|
| DCX 8510-4 | 35.60 cm | 43.74 cm | 61.29 cm | 25.40 kg | 69.00 kg |
| | 14.00 inches | 17.22 inches | 24.09 inches | 56.00 lb | 152.00 lb |
| DCX 8510-4 with Port Side Exhaust Kit | 40.00 cm | 43.74 cm | 61.29 cm | | |
| | 15.75 inches | 17.22 inches | 24.09 inches | | |
| DCX 8510-4 with door | 35.60 cm | 43.74 cm | 73.20 cm | | |
| | 14.00 inches | 17.22 inches | 28.82 inches | | |
| DCX 8510-8 | 62.23 cm | 43.74 cm | 61.29 cm | 37.30 kg | 103.38 kg |
| | 24.50 inches | 17.22 inches | 24.09 inches | 82.20 lb | 227.90 lb |
| DCX 8510-8 with door | 62.23 cm | 43.74 cm | 73.20 cm | | |
| | 24.50 inches | 17.22 inches | 28.82 inches | | |

| FRU | Description | Weight |
|---|--|---------------------|
| CP blade (CP8) | Contains the control plane for the chassis. | 3.00 kg 6.60 lb |
| CR blade (CR16-4) | Core blade for DCX 8510-4. | 3.30 kg 7.30 lb |
| CR blade (CR16-8) | Core blade for DCX 8510-8. | 3.70 kg 8.10 lb |
| FC8-32E port blade (without media) | 32-port Brocade port blade supporting 2, 4, and 8 Gbps Fibre Channel port speeds. | 2.80 kg 6.20 lb |
| FC8-48E port blade (without media) | 48-port Brocade port blade supporting 2, 4, and 8 Gbps Fibre Channel port speeds. | 3.30 kg 7.30 lb |
| FC8-64 port blade (without media) | 64-port Brocade port blade supporting 2, 4, and 8 Gbps port speeds with mSFPs. | 3.36 kg 7.40 lb |
| FC16-32 port blade (without media) | 32-port Brocade port blade supporting 2, 4, 8, 10, and 16 Gbps Fibre Channel port speeds. | 2.80 kg 6.20 lb |
| FC16-48 port blade (without media) | 48-port Brocade port blade supporting 2, 4, 8, 10, and 16 Gbps Fibre Channel port speeds. | 3.30 kg 7.30 lb |
| FC16-64 port blade (without media) | 64-port Brocade port blade supporting 4, 8, and 16 Gbps Fibre Channel port speeds. | 3.56 kg 7.85 lb |
| FCOE10-24 FCoE blade | 24-port Brocade port blade to provide FCoE support. | 3.72 kg 8.20 lb |
| FS8-18 encryption blade (without media) | Enables data cryptographic (encryption/decryption) and data compression capabilities for data-at-rest. Has 16 Fibre Channel optical SFP ports. | 5.50 kg 12.00 lb |
| FX8-24 extension blade (without media) | Enables FCIP functionality over existing IP infrastructure. Has 12 FC ports, 10 1-GbE ports, and two 10-GbE ports. | 4.20 kg 9.20 lb |
| Port card filler panel | Used when a port card is not replaced by another. | 1.50 kg 3.20 lb |
| Power supply | Redundant +48 VDC power distribution system with a provision for up to two 2000-watt, 48 VDC bulk power supplies. | 2.45 kg 5.40 lb |

| FRU | Description | Weight |
|-------------------------|--|---------------------|
| Blower assembly | Two operating blower assemblies to ensure continuous cooling of the system. | 5.73 kg 12.60 lb |
| WWN bezel | Logo plate containing the two WWN cards beneath. | 0.30 kg 0.60 lb |
| Cable management device | Brocade DCX 8510-4: Two vertical cable management finger assemblies. Brocade DCX 8510-8: One cable management comb. | 0.45 kg 1.00 lb |
| Chassis door | Chassis door for improved cable management. | 2.09 kg 4.60 lb |

Environmental requirements

| Condition | Operational | Non-operational |
|------------------------------------|--|--------------------------------------|
| Ambient temperature | 0°C to 40°C (32°F to 104°F) | -25°C to 70°C (-13°F to 158°F) |
| Relative humidity (non-condensing) | 5% to 93% at 40°C (104°F) with maximum gradient of 10% per hour | 10% to 93% at 70°C (158°F) |
| Altitude (above sea level) | 0 to 3000 m (10,000 feet) | 0 to 12000 m (40,000 feet) |
| Shock | 20 G, 6 ms, half-sine wave | 33 G, 11 ms, half-sine wave |
| Vibration | 0.5 G sine, 0.4 gms random, 5-500 Hz | 2.0 G sine, 1.1 gms random, 5-500 Hz |
| Airflow | Maximum: 90.1 cmh (53 cfm) Nominal: 59.5 cmh (35 cfm) | N/A |
| Heat dissipation | Brocade DCX 8510-4: 4078 BTU/hr Brocade DCX 8510-8: 7654 BTU/hr | N/A |

Power supply specifications (per PSU)

| Power supply model | Maximum output power rating (DC) | Input voltage | Input line frequency | Maximum input current | Input line protection | Maximum inrush current |
|--------------------|----------------------------------|---|--|-----------------------|-----------------------|--|
| XBR-DCX-0104 | 1000/2000 W | 1000 W Output 100 - 120 V (nominal) 85 - 132 V (range) | 50/60 Hz (nominal) 47 - 63 Hz (range) | 15 A | Line & Neutral Fused | 60 A peak for <10 ms <15A peak for 10 ms - 150 ms |
| | | 2000 W Output 200 - 240 V (nominal) 180 - 264 V (range) | | | | |

Power consumption (maximum configuration)

The maximum power consumption configuration features blowers at maximum speed and the FC16-48 blade configured with optics to draw the maximum MSA power per specification of 1 W (does not include the power draw for intelligent blades such as the FS18-8 or FX8-24).

| Model name | @100 VAC input | @200 VAC input | @-48 VDC input | Minimum number of power supplies | Notes |
|------------|-----------------------------------|---------------------------------|----------------|---|---|
| DCX 8510-4 | 17 A 1752 W 5979 BTU/hr | 8 A 1691 W 5773 BTU/hr | N/A | 2 for AC Low Line (100-120 VAC) 1 for AC High Line (200-240 VAC) | DCX 8510-4 fully loaded: 2 CPs, 2 Core, 4 FC16-48, 2 Fan FRUs |
| DCX 8510-8 | 25.2 A 2515.7 W 8586 BTU/hr | 12.1 A 2429 W 8290 BTU/hr | N/A | 3 for AC Low Line (100-120 VAC) 2 for AC High Line (200-240 VAC) | DCX 8510-8 fully loaded: 2 CPs, 2 Core, 8 FC16-48, 3 Fan FRUs |

Power consumption (modules)

| Module name | Module description | Maximum power consumption |
|-------------|---------------------------------------|---------------------------|
| CP8 | Control Blade | 40 W |
| CR16-8 | Core Blade for DCX 8510-8 | 240 W |
| CR16-4 | Core Blade for DCX 8510-4 | 135 W |
| FC8-32 | 32 x 8 Gbps Port Blade | 80 W |
| FC8-48 | 48 x 8 Gbps Port Blade | 115 W |
| FC8-64 | 64 x 8 Gbps Port Blade | 126 W |
| FCOE10-24 | 24 x10 Gbps Port SFP+ FCoE Port Blade | 250 W |
| FC16-32 | 32 x 16 Gbps Port Blade | 140 W |
| FC16-48 | 48 x 16 Gbps Port Blade | 160 W |
| FC16-64 | 64 x 16 Gbps QSFP Port Blade | 134 W |
| FS8-18 | Encryption Blade | 360 W |
| FX8-24 | Extension Blade | 250 W |
| Blower | Fan FRU | 90 W |

Data port specifications (Fibre Channel)

| Name | Number | Description |
|--------------------|--------|---|
| Brocade DCX 8510-4 | 192 | 16 Gbps (E, F, D, M, and EX) Fibre Channel ports using four 48-port 16 Gbps Fibre Channel blades |
| | 256 | 8 Gbps (E, F, D, M, and EX) Fibre Channel ports using four 64-port 8 Gbps Fibre Channel blades |
| Brocade DCX 8510-8 | 384 | 16 Gbps (E, F, D, M, and EX) Fibre Channel ports using eight 48-port 16 Gbps Fibre Channel blades |
| | 512 | 8 Gbps (E, F, D, M, and EX) Fibre Channel ports using eight 64-port 8 Gbps Fibre Channel blades |

Fibre Channel data transmission ranges

| Port speed (Gbps) | Cable size (microns) | Short wavelength (SWL) | Long wavelength (LWL) | Extended long wavelength (ELWL) |
|-------------------|----------------------|------------------------|---|---------------------------------|
| 2 | 50 | 300 m (984 ft) (OM2) | N/A | N/A |
| | | 500 m (1,640 ft) (OM3) | | |
| | | 62.5 | 150 m (492 ft) | N/A |
| | 9 | N/A | 30 km (18.6 miles) | N/A |
| 4 | 50 | 150 m (492 ft) (OM2) | N/A | N/A |
| | | 380 m (1,246 ft) (OM3) | | |
| | | 400 m (1,312 ft) (OM4) | | |
| | 62.5 | 70 m (230 ft) | N/A | N/A |
| | 9 | N/A | 30 km (18.6 miles) | N/A |
| 8 | 50 | 50 m (164 ft) (OM2) | N/A | N/A |
| | | 150 m (492 ft) (OM3) | | |
| | | 190 m (623 ft) (OM4) | | |
| | 62.5 | 21 m (69 ft) | N/A | N/A |
| | 9 | N/A | 10 km (6.2 miles) or 40 km (24.8 miles) | N/A |
| 10 | 50 | 82 m (269 ft) (OM2) | N/A | N/A |
| | | 300 m (984 ft) (OM3) | | |
| | | 550 m (1804 ft) (OM4) | | |
| | 62.5 | 33 m (108 ft) | N/A | N/A |
| | 9 | N/A | 10 km (6.2 miles) | N/A |
| 16 | 50 | 35 m (115 ft) (OM2) | N/A | N/A |
| | | 100 m (328 ft) (OM3) | | |
| | | 125 m (410 ft) (OM4) | | |
| | 62.5 | 15 m (49 ft) | N/A | N/A |
| | 9 | N/A | 10 km (6.2 miles) | N/A |

| Port speed (Gbps) | Cable size (microns) | Short wavelength (SWL) | Long wavelength (LWL) | Extended long wavelength (ELWL) |
|-------------------|----------------------|------------------------|-----------------------|---------------------------------|
| 4 x 16 | 50 | 50 m (49 ft) | N/A | N/A |
| | 62.5 | N/A | N/A | N/A |
| | 9 | N/A | N/A | N/A |

Serial port specifications (DB9)

| Pin | Signal | Description |
|-----|--------------|---------------|
| 1 | Reserved | Reserved |
| 2 | TXD (output) | Transmit data |
| 3 | RXD (input) | Receive data |
| 4 | Reserved | Reserved |
| 5 | GND | Logic ground |
| 6 | Reserved | Reserved |
| 7 | Reserved | Reserved |
| 8 | Reserved | Reserved |
| 9 | Reserved | Reserved |

Serial port specifications (pinout mini-USB)

| Pin | Signal | Description |
|-----|----------|--------------|
| 1 | +5V | Not used |
| 2 | UART0_TX | Debug port |
| 3 | UART0_RX | Console port |
| 4 | IN | Not used |
| 5 | GND | Ground |

Serial port specifications (pinout RJ-45)

| Pin | Signal | Description |
|-----|---------------|---------------|
| 1 | Not supported | N/A |
| 2 | Not supported | N/A |
| 3 | UART1_TXD | Transmit data |
| 4 | GND | Logic ground |
| 5 | GND | Logic ground |
| 6 | UART1_RXD | Receive data |
| 7 | Not supported | N/A |
| 8 | Not supported | N/A |

Serial port specifications (protocol)

| Parameter | Value |
|--------------|-------|
| Baud | 9600 |
| Data bits | 8 |
| Parity | None |
| Stop bits | 1 |
| Flow control | None |

Regulatory compliance (EMC)

- FCC Part 15, Subpart B
- ICES-3 (A) / NMB-3(A)
- CISPR22 and JEIDA
- EN55022 and EN55024
- EN 55022 or CISPR22 or AS/NZS CISPR22
- 51318.22-99 and 51318.24.99
- 8KN22 and KN24
- GB 9254-2008
- CNS 13438:95
- EN55022 Class A

Regulatory compliance (safety)

- Bi-Nat UL/CSA 60950-1 1st Ed
- EN60950-1
- IEC60950-1
- GB 4943.1-2011
- CNS 14336-1:99

Regulatory compliance (environmental)

- 2011/65/EU - Restriction of the use of certain hazardous substance in electrical and electronic equipment (EU RoHS).
- 2012/19/EU - Waste electrical and electronic equipment (EU WEEE).
- 94/62/EC - packaging and packaging waste (EU).
- 2006/66/EC - batteries and accumulators and waste batteries and accumulators (EU battery directive).
- 1907/2006 of the European Parliament and of the Council of 18 December 2006 concerning the Registration, Evaluation, Authorisation and Restriction of Chemicals (EU REACH).
- Section 1502 of the Dodd-Frank Wall Street Reform and Consumer Protection Act of 2010 - U.S. Conflict Minerals.
- 30/2011/TT-BCT - Vietnam circular.
- SJ/T 11363-2006 Requirements for Concentration Limits for Certain Hazardous Substances in EIPs (China).
- SJ/T 11364-2006 Marking for the Control of Pollution Caused by EIPs (China).

Caution and Danger Notices

- [Cautions](#)..... 167
- [Danger Notices](#)..... 168

Cautions

A caution calls your attention to a possible hazard that can damage equipment.

"Vorsicht" weist auf die Gefahr einer möglichen Beschädigung des Gerätes hin.

Une mise en garde attire votre attention sur un risque possible d'endommagement de l'équipement. Ci-dessous, vous trouverez les mises en garde utilisées dans ce manuel.

Un mensaje de precaución le advierte sobre un posible peligro que pueda dañar el equipo. Las siguientes son precauciones utilizadas en este manual.

Electrical cautions



CAUTION

Use a separate branch circuit for each power cord, which provides redundancy in case one of the circuits fails.

| | |
|----------|---|
| VORSICHT | Es empfiehlt sich die Installation eines separaten Stromkreisweiges für jede Elektroschnur als Redundanz im Fall des Ausfalls eines Stromkreises. |
|----------|---|

| | |
|---------------|--|
| MISE EN GARDE | Utilisez un circuit de dérivation différent pour chaque cordon d'alimentation ainsi, il y aura un circuit redondant en cas de panne d'un des circuits. |
|---------------|--|

| | |
|------------|--|
| PRECAUCIÓN | Use un circuito derivado separado para cada cordón de alimentación, con lo que se proporcionará redundancia en caso de que uno de los circuitos falle. |
|------------|--|



CAUTION

Before plugging a cable into to any port, be sure to discharge the voltage stored on the cable by touching the electrical contacts to ground surface.

| | |
|----------|--|
| VORSICHT | Bevor Sie ein Kabel in einen Anschluss einstecken, entladen Sie jegliche im Kabel vorhandene elektrische Spannung, indem Sie mit den elektrischen Kontakten eine geerdete Oberfläche berühren. |
|----------|--|

| | |
|---------------|---|
| MISE EN GARDE | Avant de brancher un câble à un port, assurez-vous de décharger la tension du câble en reliant les contacts électriques à la terre. |
|---------------|---|

PRECAUCIÓN Antes de conectar un cable en cualquier puerto, asegúrese de descargar la tensión acumulada en el cable tocando la superficie de conexión a tierra con los contactos eléctricos.



CAUTION

Static electricity can damage the chassis and other electronic devices. To avoid damage, keep static-sensitive devices in their static-protective packages until you are ready to install them.

VORSICHT Statische Elektrizität kann das System und andere elektronische Geräte beschädigen. Um Schäden zu vermeiden, entnehmen Sie elektrostatisch empfindliche Geräte erst aus deren antistatischer Schutzhülle, wenn Sie bereit für den Einbau sind.

MISE EN GARDE L'électricité statique peut endommager le châssis et les autres appareils électroniques. Pour éviter tout dommage, conservez les appareils sensibles à l'électricité statique dans leur emballage protecteur tant qu'ils n'ont pas été installés.

PRECAUCIÓN La electricidad estática puede dañar el chasis y otros dispositivos electrónicos. A fin de impedir que se produzcan daños, conserve los dispositivos susceptibles de dañarse con la electricidad estática dentro de los paquetes protectores hasta que esté listo para instalarlos.



CAUTION

If you do not install a module or a power supply in a slot, you must keep the slot filler panel in place. If you run the chassis with an uncovered slot, the system will overheat.

VORSICHT Falls kein Modul oder Netzteil im Steckplatz installiert wird, muss die Steckplatztafel angebracht werden. Wenn ein Steckplatz nicht abgedeckt wird, läuft das System heiß.

MISE EN GARDE Si vous n'installez pas de module ou de bloc d'alimentation dans un slot, vous devez laisser le panneau du slot en place. Si vous faites fonctionner le châssis avec un slot découvert, le système surchauffera.

PRECAUCIÓN Si no instala un módulo o un fuente de alimentación en la ranura, deberá mantener el panel de ranuras en su lugar. Si pone en funcionamiento el chasis con una ranura descubierta, el sistema sufrirá sobrecalentamiento.

Danger Notices

A danger notification calls your attention to a possible hazard that can cause injury or death. The following are the warnings used in this manual.

"Gefahr" weist auf eine mögliche Gefährdung hin, die zu Verletzungen oder Tod führen können. Sie finden die folgenden Warnhinweise in diesem Handbuch.

Un danger attire votre attention sur un risque possible de blessure ou de décès. Ci-dessous, vous trouverez les avertissements utilisés dans ce manuel.

Una señal de peligro le llama la atención sobre cualquier posible peligro que pueda ocasionar daños personales o la muerte. A continuación se dan las advertencias utilizadas en este manual.

Electrical dangers



DANGER

Make sure that the power source circuits are properly grounded, then use the power cord supplied with the device to connect it to the power source.

GEFAHR Stellen Sie sicher, dass die Stromkreise ordnungsgemäß geerdet sind. Benutzen Sie dann das mit dem Gerät gelieferte Stromkabel, um es an die Stromquelle anzuschließen.

DANGER Vérifiez que les circuits de sources d'alimentation sont bien mis à la terre, puis utilisez le cordon d'alimentation fourni avec le dispositif pour le connecter à la source d'alimentation.

PELIGRO Verifique que circuitos de la fuente de corriente están conectados a tierra correctamente; luego use el cordón de potencia suministrado con el instrumento para conectarlo a la fuente de corriente



DANGER

For safety reasons, the ESD wrist strap should contain a series 1 megaohm resistor.

GEFAHR Aus Sicherheitsgründen sollte ein EGB-Armband zum Schutz von elektronischen gefährdeten Bauelementen mit einem 1 Megaohm-Reihenwiderstand ausgestattet sein.

DANGER Pour des raisons de sécurité, la dragonne ESD doit contenir une résistance de série 1 méga ohm.

PELIGRO Por razones de seguridad, la correa de muñeca ESD deberá contener un resistor en serie de 1 mega ohmio.



DANGER

Remove both power cords before servicing.

GEFAHR Trennen Sie beide Netzkabel, bevor Sie Wartungsarbeiten durchführen.

DANGER Retirez les deux cordons d'alimentation avant toute maintenance.

PELIGRO Desconecte ambos cables de alimentación antes de realizar reparaciones.



DANGER

Disconnect the power cord from all power sources to completely remove power from the device.

GEFAHR Ziehen Sie das Stromkabel aus allen Stromquellen, um sicherzustellen, dass dem Gerät kein Strom zugeführt wird.

DANGER Débranchez le cordon d'alimentation de toutes les sources d'alimentation pour couper complètement l'alimentation du dispositif.

PELIGRO Para desconectar completamente la corriente del instrumento, desconecte el cordón de corriente de todas las fuentes de corriente.



DANGER

If the installation requires a different power cord than the one supplied with the device, make sure you use a power cord displaying the mark of the safety agency that defines the regulations for power cords in your country. The mark is your assurance that the power cord can be used safely with the device.

GEFAHR Falls für die Installation ein anderes Stromkabel erforderlich ist (wenn das mit dem Gerät gelieferte Kabel nicht passt), müssen Sie sicherstellen, dass Sie ein Stromkabel mit dem Siegel einer Sicherheitsbehörde verwenden, die für die Zertifizierung von Stromkabeln in Ihrem Land zuständig ist. Das Siegel ist Ihre Garantie, dass das Stromkabel sicher mit Ihrem Gerät verwendet werden kann.

DANGER Si l'installation nécessite un cordon d'alimentation autre que celui fourni avec le dispositif, assurez-vous d'utiliser un cordon d'alimentation portant la marque de l'organisation responsable de la sécurité qui définit les normes et réglementations pour les cordons d'alimentation dans votre pays. Cette marque vous assure que vous pouvez utiliser le cordon d'alimentation avec le dispositif en toute sécurité.

PELIGRO Si la instalación requiere un cordón de corriente distinto al que se ha suministrado con el instrumento, verifique que usa un cordón de corriente que venga con la marca de la agencia de seguridad que defina las regulaciones para cordones de corriente en su país. Esta marca será su garantía de que el cordón de corriente puede ser utilizado con seguridad con el instrumento.

Dangers related to equipment weight



DANGER

Use safe lifting practices when moving the product.

GEFAHR Beim Bewegen des Produktes ist auf eine sichere Hubtechnik zu achten.

DANGER Utiliser des techniques de levage sûres pour déplacer le produit.

PELIGRO Tenga mucho cuidado al levantar el producto para moverlo



DANGER

A fully populated Brocade DCX 8510-8 (eight FC16-64 port cards, 512 ports) weighs approximately 161.2 kg (355 lbs) and requires a hydraulic or assisted lift to install it.

GEFAHR Ein vollständig bestückter Brocade DCX 8510-8 (acht FC16-64-Port-Karten, 512 Ports) wiegt etwa 161.2 kg und erfordert zur Installation eine hydraulische oder Servo-Hebevorrichtung.

| | |
|--------|---|
| DANGER | Un commutateur Brocade DCX 8510-8 complet (huit cartes de port FC16-64, 512 ports) pèse environ 161.2 kg et requiert un dispositif de levage hydraulique ou électrique pour l'installation. |
|--------|---|

| | |
|---------|---|
| PELIGRO | Un Brocade DCX 8510-8 con la configuración completa (ocho tarjetas para puertos FC16-64, 512 puertos) pesa aproximadamente 161.2 kg (355 libras) y requiere un elevador hidráulico o asistido para realizar su instalación. |
|---------|---|

Index

10 GbE ports [127](#)

A

application blade
 determining status [54](#)
 replacing [78](#)

B

backbone configuration [35](#)
back up configuration [47](#)
bezel, WWN, replacing [99](#)
blade
 CP, LEDs [65](#)
 FCOE10-24 [129](#)
 FS8-18 [127](#)
 FX8-24 [127](#)
 port, LEDs [54](#)
blades
 application, replacing [78](#)
 CR, LEDs [67](#)
 encryption, replacing [78](#)
 port, replacing [78](#)
 support for [13](#)
blower assembly
 LEDs [70](#)
 replacing [98](#)
 status [70](#)
boot results, interpreting [132](#)
BSMI statement (Taiwan) [150](#)

C

cable management comb, replacing [77](#)
cables

 attach SFP [43](#)
 for FC8-64 [31](#)
 managing [29](#), [46](#)
 QSFP [33](#), [46](#), [108](#)
Canadian requirement [151](#)
certifications [149](#), [151](#)
CE statement [150](#)
chassis, replacing [113](#)
chassis door, replacing [76](#)
chassis hardware components [14](#)
chassis name, customizing [40](#)
chassisName command [40](#)
China RoHS [152](#)
command
 chassisName [40](#)
 configShow [47](#)
 configUpload [47](#)
 configUpload -vf [47](#)
 configure [40](#), [43](#)
 date [41](#)
 fabricShow [40](#), [44](#), [47](#)
 frureplace [100](#)
 ipaddrSet [38](#)
 ipaddrSet -chassis [38](#)
 ipaddrSet -cp0 [38](#)
 ipaddrSet -cp1 [38](#)
 ipAddrShow [38](#), [47](#)
 licenseIdShow [43](#)
 licenseShow [43](#), [47](#)
 logout [39](#)
 slotShow [54](#)
 switchDisable [40](#)
 switchEnable [40](#)
 switchName [40](#)
 switchShow [44](#), [47](#)
 switchShow -qsfp [45](#)
 sysShutdown [48](#)
 tsClockServer [42](#)
 tsTimeZone [41](#)
 usbStorage [47](#)
compliance, environmental regulation [152](#)
configShow command [47](#)
configUpload command [47](#)
configUpload -vf command [47](#)
configuration, backbone [35](#)
configuration backup [47](#)
configuration data

- troubleshooting [134](#)
- configure command [40](#), [43](#)
- configuring IP address [38](#)
- core switch blade
 - determining status [67](#)
 - replacing [94](#)
- CP blade
 - determining status [65](#)
 - replacing [84](#)
 - troubleshooting [134](#)
 - verifying operation [88](#)
- CR blade
 - determining status [92](#)
 - removing [92](#)
 - replacing [92](#)
- customizing
 - chassis name [40](#)
 - switch name [40](#)

D

- date, setting [41](#)
- date command [41](#)
- diagnostics
 - boot results [132](#)
 - POST [132](#)
- diagnostic tests [133](#)
- domain ID
 - setting [40](#)
- domain IDs
 - troubleshooting [134](#)

E

- encryption blade [127](#)
- encryption blade, replacing [78](#)
- environmental regulation compliance [152](#)
- error messages, WWN card [72](#)
- Ethernet, establish connection [39](#)
- Ethernet link speed
 - troubleshooting [134](#)
- extension blade [127](#)

F

- fabricShow command [40](#), [44](#), [47](#)
- FC8-64

- qualified cables [31](#)
- FCC warning (US only) [149](#)
- FCIP [127](#)
- FCOE10-24 [129](#)
- FCoE blade [129](#)
- FC trunking groups [127](#)
- features, software [20](#)
- Fibre Channel Routing Services [127](#)
- field-replaceable units
 - See FRUs [14](#)
- filler panel, replacing [82](#)
- firmwaredownload
 - from USB [90](#)
- frureplace command [100](#)
- FRUs
 - application blade
 - replacing [78](#)
 - blower assembly
 - LEDs [70](#)
 - replacing [98](#)
 - cable management comb
 - replacing [77](#)
 - chassis
 - replacing [113](#)
 - chassis door
 - replacing [76](#)
 - CP blade
 - LEDs [65](#)
 - replacing [84](#)
 - CR blade
 - LEDs [67](#)
 - replacing [92](#)
 - encryption blade
 - replacing [78](#)
 - filler panel, replacing [82](#)
 - port blade
 - LEDs [54](#)
 - replacing [78](#)
 - power supply
 - LEDs [69](#)
 - replacing [95](#)
 - QSFP cables
 - replacing [108](#)
 - SFP [43](#)
 - transceivers, replacing [103](#)
 - troubleshooting [134](#)
 - WWN bezel
 - replacing [99](#)
 - WWN card
 - replacing [99](#)
- FS8-18 blade [127](#)
- FX8-24 blade [127](#)

G

GbE ports [127](#)

H

high availability [19](#)

I

installation

items required [24](#)

SFP [43](#)

installation tasks [23](#)

installed licenses [43](#)

inter-chassis linking (ICL) See QSFP cables\ [108](#)

inter-chassis linking (QSFP) [33](#), [46](#), [108](#)

IP address, configuring [38](#)

ipaddrSet -chassis command [38](#)

ipaddrSet command [38](#)

ipaddrSet -cp0 command [38](#)

ipaddrSet -cp1 command [38](#)

ipAddrShow command [38](#), [47](#)

K

KCC statement (Republic of Korea) [149](#)

L

LEDs

blower assembly [70](#)

CP blade [65](#)

CR blade [67](#)

port blade [54](#)

power supply [69](#)

troubleshooting [134](#)

license, chassis software [43](#)

licenseIdShow command [43](#)

licenseShow command [43](#), [47](#)

local time, synchronizing [42](#)

logout command [39](#)

M

manageability, network [21](#)

managing cables [46](#)

N

NTP server, external [42](#)

numbering, port [27](#)

P

PID mode [43](#)

port

numbering [27](#)

numbering template [137](#)

port blade

determining status [54](#)

replacing [78](#)

troubleshooting [134](#)

port identifier mode [43](#)

POST, interpreting [132](#)

power, providing [27](#)

power supply

LEDs [69](#)

replacing [95](#)

status [69](#)

Q

QSFP cables

installing [108](#)

replacing [108](#)

QSFPs

as inter-chassis links [45](#)

QSFP transceivers [108](#)

R

rack space requirement [24](#)

regulatory compliance [149](#)

reliability, features [19](#)

removal and replacement procedure

See RRP [75](#)

RRP

- application blade [78](#)
- blade filler panel [82](#)
- blower assembly [98](#)
- cable management comb [77](#)
- chassis [113](#)
- chassis door [76](#)
- CP blade [84](#)
- CR blade [92](#)
- encryption blade [78](#)
- port blade [78](#)
- power supply [95](#)
- QSFP cables [108](#)
- transceivers [103](#)
- WWN bezel [99](#)
- WWN card [99](#)

S

- safety guidelines [24](#)
- security [20](#)
- serial connection
 - establishing [36](#)
 - troubleshooting [134](#)
- serial port logout [39](#)
- serviceability, features [20](#)
- setting
 - time zone [41](#)
- SFPs [43](#)
- site planning [24](#)
- slotShow command [54](#)
- software features [20](#)
- status
 - application blade [54](#)
 - blower assembly [70](#)
 - core switch blade [67](#)
 - CP blade [65](#)
 - port blade [54](#)
 - power supply [69](#)
 - WWN card [72](#)
- switch
 - connect to [37](#)
 - domain ID [40](#)
- switchDisable command [40](#)
- switchEnable command [40](#)
- switch name
 - customizing [40](#)
 - length [40](#)
- switchName command [40](#)
- switchShow command [44](#), [47](#)
- switchShow -qsfp command [45](#)
- sysShutdown command [48](#)

T

- tasks, installation [23](#)
- template, port numbering [137](#)
- terminal emulator, configuring [36](#)
- tool, extraction, transceivers [103](#)
- transceivers
 - extraction tool [103](#)
 - QSFP [108](#)
 - replacing [103](#)
 - supported types [26](#)
- troubleshooting
 - chassis power [134](#)
 - configuration data [134](#)
 - CP blade [134](#)
 - domain IDs [134](#)
 - Ethernet link speed [134](#)
 - FRUs [134](#)
 - general [131](#)
 - IP addresses [134](#)
 - LEDs [134](#)
 - port blade [134](#)
 - serial connection [134](#)
- trunking groups [127](#)
- tsClockServer command [42](#)
- tsTimeZone command [41](#)

U

- usbStorage command [47](#)

V

- VCCI statement [149](#)
- verifying, CP blade operation [88](#)

W

- WWN bezel
 - replacing [99](#)
- WWN card
 - determining status [72](#)
 - error messages [72](#)
 - preparing for replacement [100](#)
 - replacing [99](#)
 - verifying need to replace [100](#)